

## Q6.1

An elevator is being *lifted* at a constant speed by a steel cable attached to an electric motor. Which statement is correct?

A. The cable does positive work on the elevator, and the elevator does positive work on the cable.

B. The cable does positive work on the elevator, and the elevator does negative work on the cable.

C. The cable does negative work on the elevator, and the elevator does positive work on the cable.

D. The cable does negative work on the elevator, and the elevator does negative work on the cable.

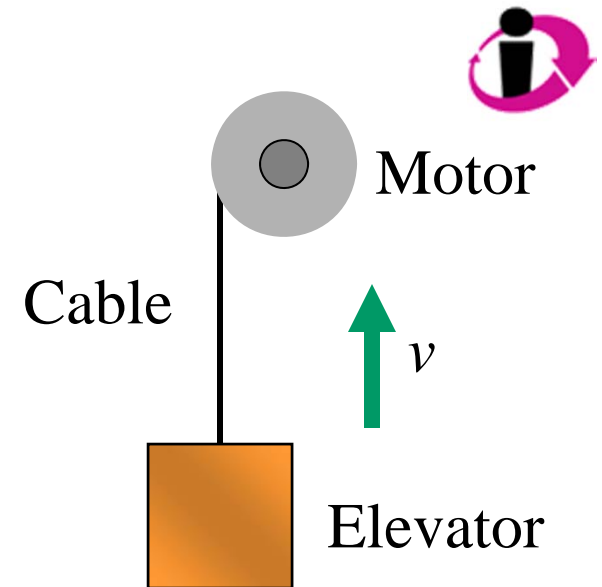

## A6.1

An elevator is being *lifted* at a constant speed by a steel cable attached to an electric motor. Which statement is correct?

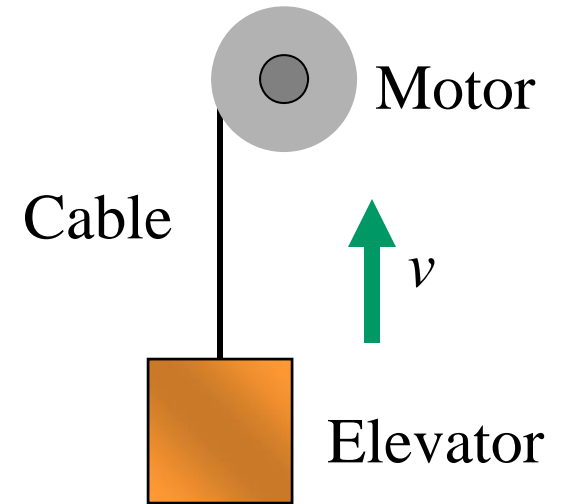

- A. The cable does positive work on the elevator, and the elevator does positive work on the cable.
- ✓ B. The cable does positive work on the elevator, and the elevator does negative work on the cable.
- C. The cable does negative work on the elevator, and the elevator does positive work on the cable.
- D. The cable does negative work on the elevator, and the elevator does negative work on the cable.

## Q6.2

An elevator is being *lowered* at a constant speed by a steel cable attached to an electric motor. Which statement is correct?

A. The cable does positive work on the elevator, and the elevator does positive work on the cable.

B. The cable does positive work on the elevator, and the elevator does negative work on the cable.

C. The cable does negative work on the elevator, and the elevator does positive work on the cable.

D. The cable does negative work on the elevator, and the elevator does negative work on the cable.

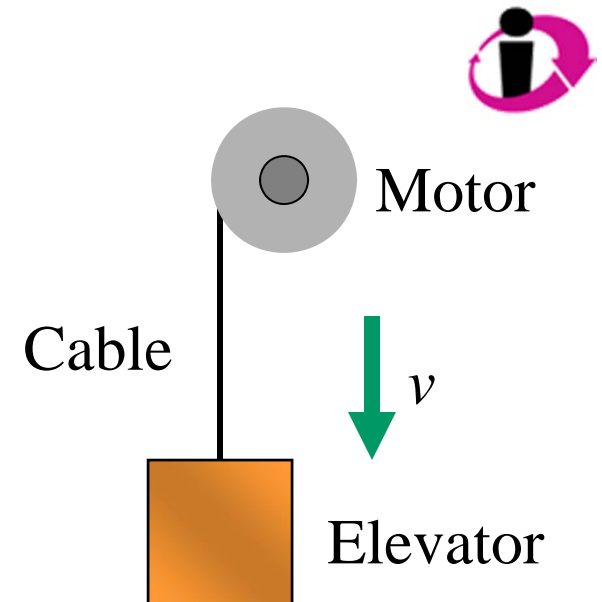

## A6.2

An elevator is being *lowered* at a constant speed by a steel cable attached to an electric motor. Which statement is correct?

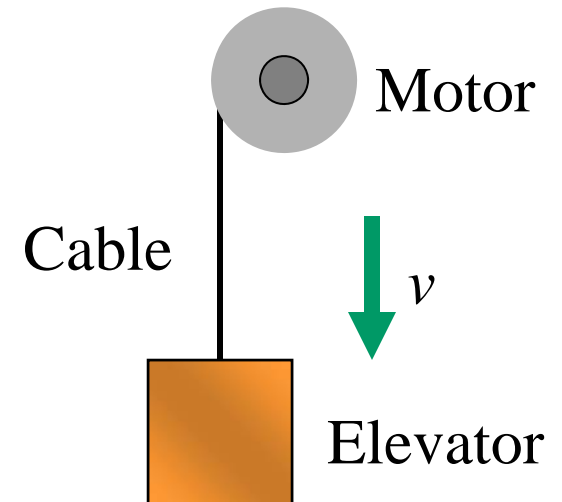

- A. The cable does positive work on the elevator, and the elevator does positive work on the cable.
- B. The cable does positive work on the elevator, and the elevator does negative work on the cable.
- ✓ C. The cable does negative work on the elevator, and the elevator does positive work on the cable.
- D. The cable does negative work on the elevator, and the elevator does negative work on the cable.

## Q6.3



Two iceboats (one of mass  $m$ , one of mass  $2m$ ) hold a race on a frictionless, horizontal, frozen lake. Both iceboats start at rest, and the wind exerts the same constant force on both iceboats.

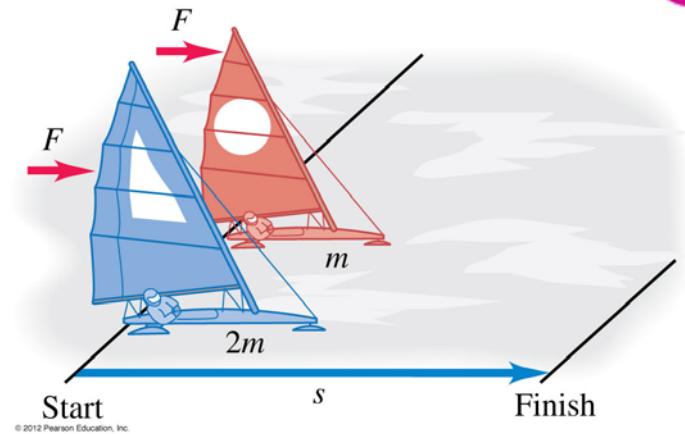

Which iceboat crosses the finish line with more kinetic energy (KE)?

- A. The iceboat of mass  $m$ : it has twice as much KE as the other.
- B. The iceboat of mass  $m$ : it has 4 times as much KE as the other.
- C. The iceboat of mass  $2m$ : it has twice as much KE as the other.
- D. The iceboat of mass  $2m$ : it has 4 times as much KE as the other.
- E. They both cross the finish line with the same kinetic energy.

## A6.3

Two iceboats (one of mass  $m$ , one of mass  $2m$ ) hold a race on a frictionless, horizontal, frozen lake. Both iceboats start at rest, and the wind exerts the same constant force on both iceboats.

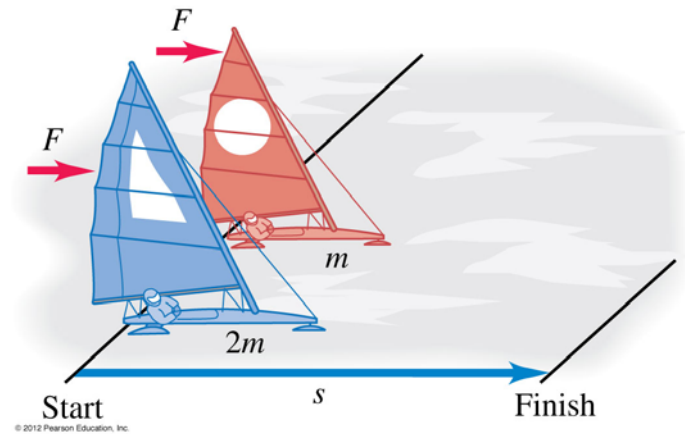

Which iceboat crosses the finish line with more kinetic energy (KE)?

- A. The iceboat of mass  $m$ : it has twice as much KE as the other.
- B. The iceboat of mass  $m$ : it has 4 times as much KE as the other.
- C. The iceboat of mass  $2m$ : it has twice as much KE as the other.
- D. The iceboat of mass  $2m$ : it has 4 times as much KE as the other.
- ✓ E. They both cross the finish line with the same kinetic energy.

## Q6.4



A tractor driving at a constant speed pulls a sled loaded with firewood. There is friction between the sled and the road.

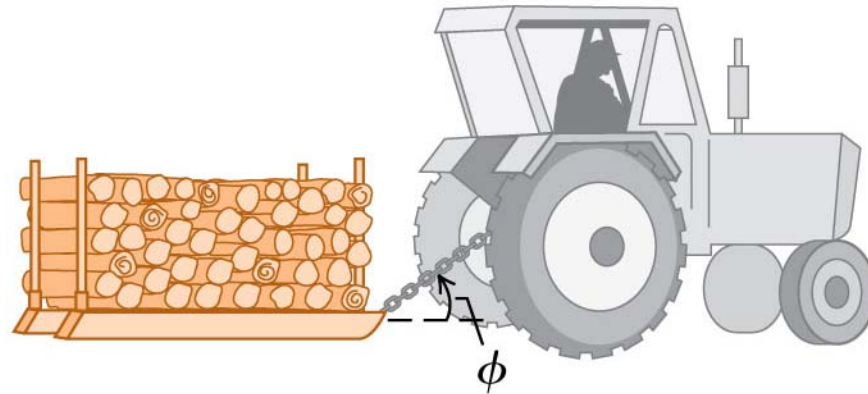

© 2012 Pearson Education, Inc.

The total work done on the sled after it has moved a distance  $d$  is

- A. positive.
- B. negative.
- C. zero.
- D. not enough information given to decide

## A6.4

A tractor driving at a constant speed pulls a sled loaded with firewood. There is friction between the sled and the road.

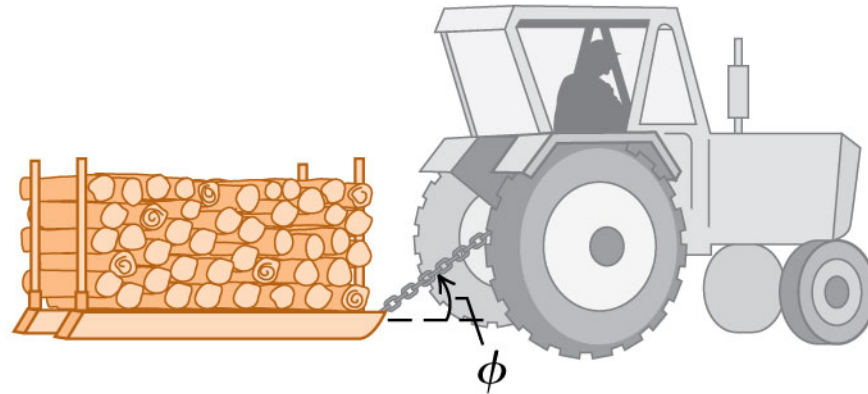

© 2012 Pearson Education, Inc.

The total work done on the sled after it has moved a distance  $d$  is

- A. positive.
- B. negative.
- C. zero.
- D. not enough information given to decide



Q6.5



A nonzero net force acts on an object. Which of the following quantities could be *constant*?

- A. the object's kinetic energy
- B. the object's velocity
- C. both of the above
- D. none of the above

## A6.5

A nonzero net force acts on an object. Which of the following quantities could be *constant*?

- A. the object's kinetic energy
- B. the object's velocity
- C. both of the above
- D. none of the above

## Q6.6



A 6.00-kg block and an 8.00-kg block are connected as shown. When released, the 6.00-kg block accelerates downward and the 8.00-kg block accelerates to the right. After each block has moved 2.00 cm, the force of gravity has done

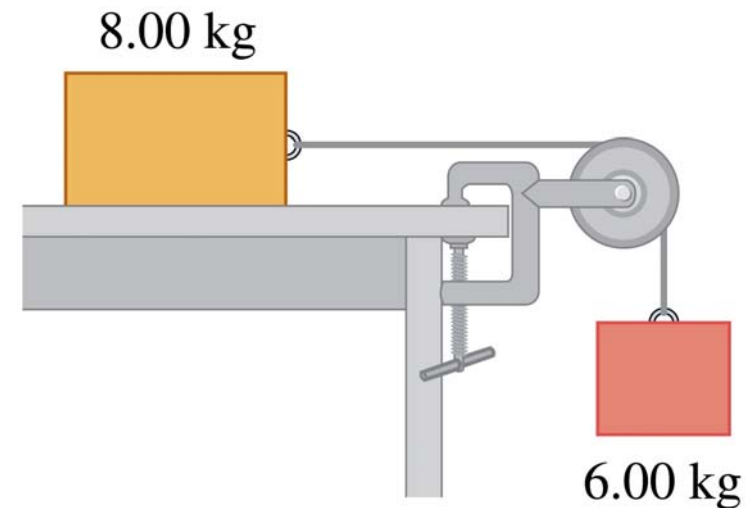

- A. more work on the 8.00-kg block than on the 6.00-kg block.
- B. the same amount of work on both blocks.
- C. less work on the 8.00-kg block than on the 6.00-kg block.
- D. not enough information given to decide

## A6.6

A 6.00-kg block and an 8.00-kg block are connected as shown. When released, the 6.00-kg block accelerates downward and the 8.00-kg block accelerates to the right. After each block has moved 2.00 cm, the force of gravity has done

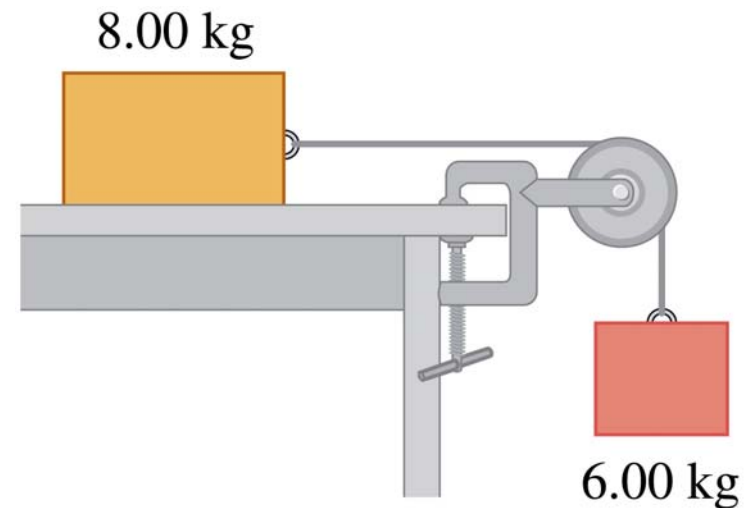

- A. more work on the 8.00-kg block than on the 6.00-kg block.
- B. the same amount of work on both blocks.
- ✓ C. less work on the 8.00-kg block than on the 6.00-kg block.
- D. not enough information given to decide

## Q6.7

A 6.00-kg block and an 8.00-kg block are connected as shown. When released, the 6.00-kg block accelerates downward and the 8.00-kg block accelerates to the right. After each block has moved 2.00 cm, the total work done on the 8.00-kg block

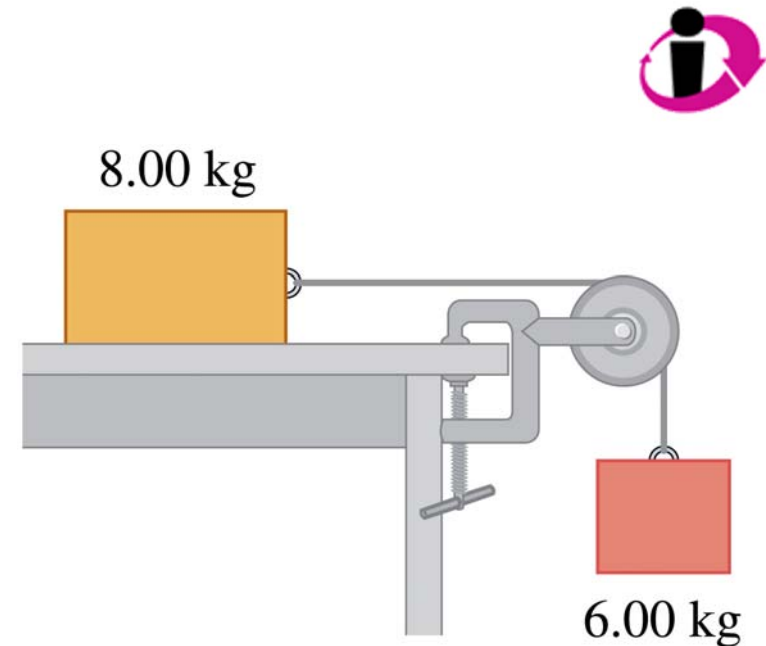

- A. is greater than the total work done on the 6.00-kg block.
- B. is the same as the total work done on the 6.00-kg block.
- C. is less than the total work done on the 6.00-kg block.
- D. not enough information given to decide

## A6.7

A 6.00-kg block and an 8.00-kg block are connected as shown. When released, the 6.00-kg block accelerates downward and the 8.00-kg block accelerates to the right. After each block has moved 2.00 cm, the total work done on the 8.00-kg block

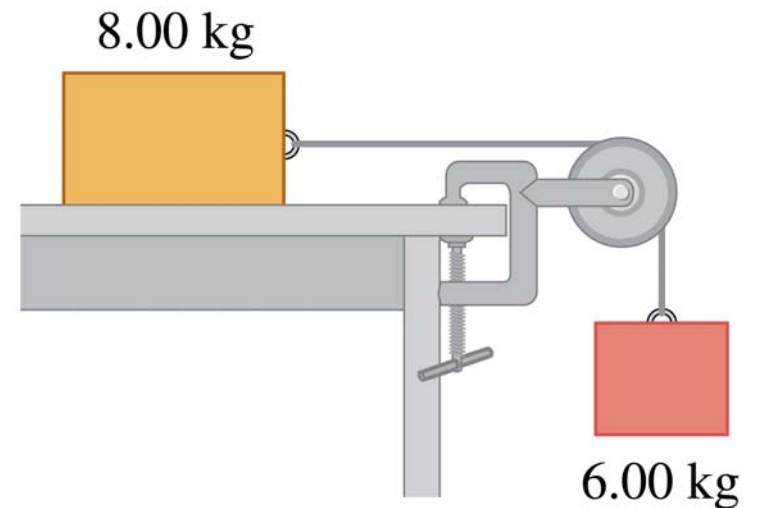

- ✓ A. is greater than the total work done on the 6.00-kg block.
- B. is the same as the total work done on the 6.00-kg block.
- C. is less than the total work done on the 6.00-kg block.
- D. not enough information given to decide

## Q6.8

Three blocks are connected as shown. The ropes and pulleys are of negligible mass. When released, block  $C$  moves downward, block  $B$  moves up the ramp, and block  $A$  moves to the right.

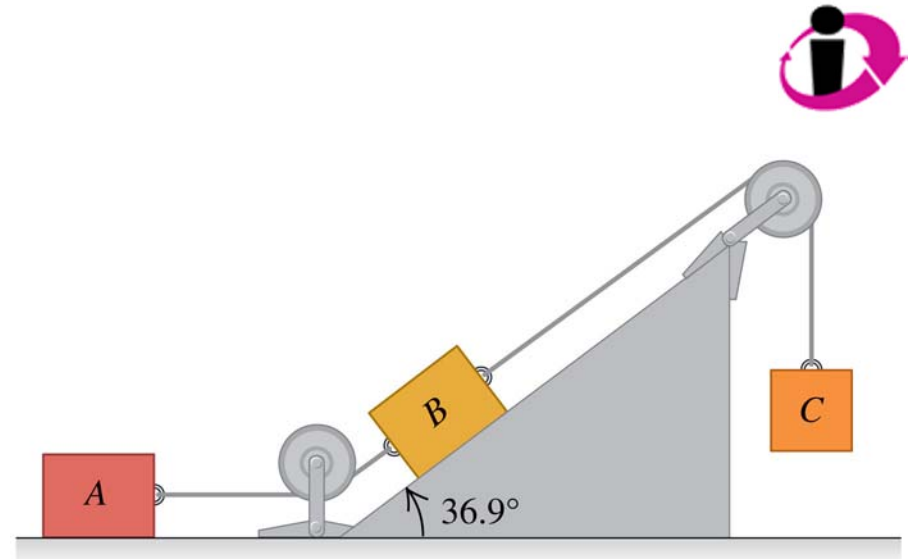

After each block has moved a distance  $d$ , the force of gravity has done

- A. positive work on  $A$ ,  $B$ , and  $C$ .
- B. zero work on  $A$ , positive work on  $B$ , and negative work on  $C$ .
- C. zero work on  $A$ , negative work on  $B$ , and positive work on  $C$ .
- D. none of these

## A6.8

Three blocks are connected as shown. The ropes and pulleys are of negligible mass. When released, block  $C$  moves downward, block  $B$  moves up the ramp, and block  $A$  moves to the right.

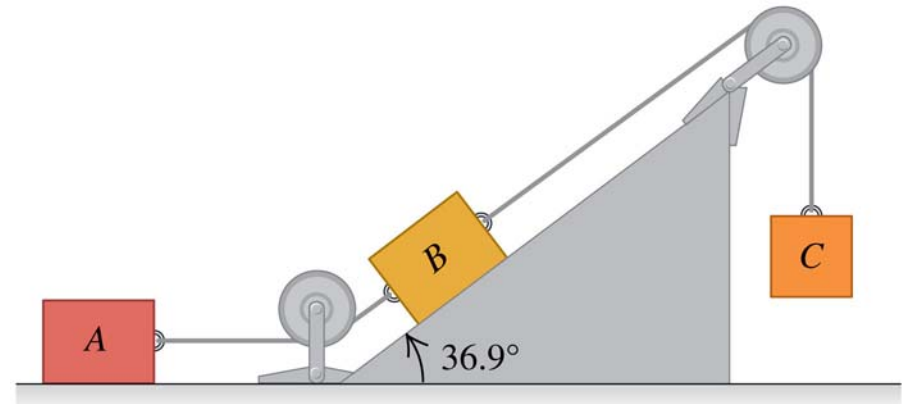

After each block has moved a distance  $d$ , the force of gravity has done

- A. positive work on  $A$ ,  $B$ , and  $C$ .
- B. zero work on  $A$ , positive work on  $B$ , and negative work on  $C$ .
- ✓ C. zero work on  $A$ , negative work on  $B$ , and positive work on  $C$ .
- D. none of these



## Q6.9

Two blocks are connected as shown. The rope and pulley are of negligible mass. When released, the block of mass  $m_1$  slides down the ramp and the block of mass  $m_2$  moves upward.

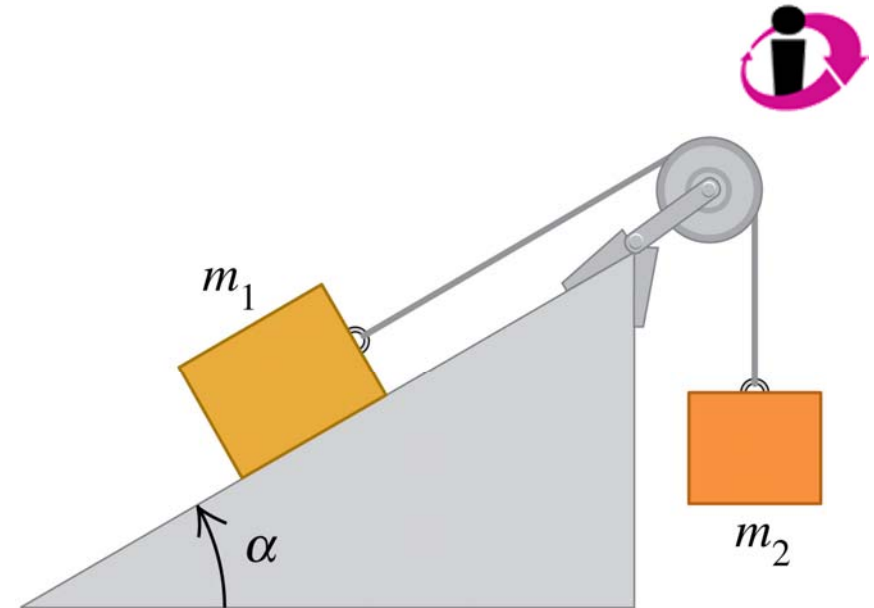

After each block has moved a distance  $d$ , the total work done on  $m_1$

- A. is greater than the total work done on  $m_2$ .
- B. is the same as the total work done on  $m_2$ .
- C. is less than the total work done on  $m_2$ .
- D. not enough information given to decide

## A6.9

Two blocks are connected as shown. The rope and pulley are of negligible mass. When released, the block of mass  $m_1$  slides down the ramp and the block of mass  $m_2$  moves upward.

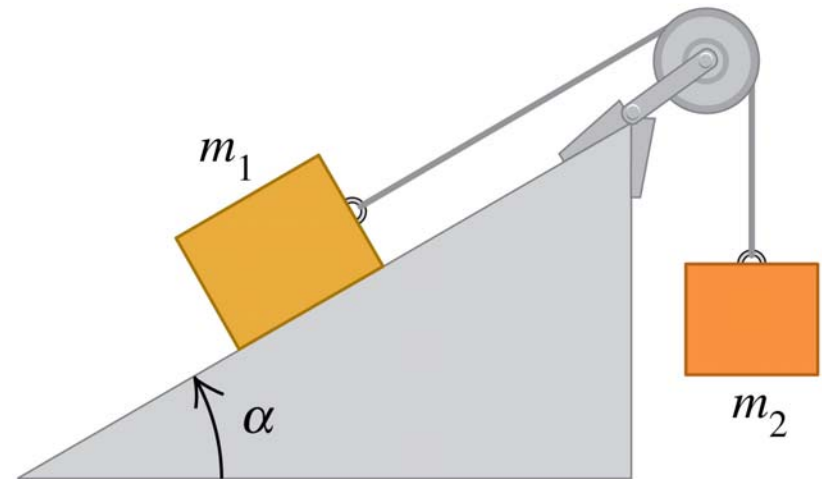

After each block has moved a distance  $d$ , the total work done on  $m_1$

- ✓ A. is greater than the total work done on  $m_2$ .
- B. is the same as the total work done on  $m_2$ .
- C. is less than the total work done on  $m_2$ .
- D. not enough information given to decide

## Q6.10



An object is initially at rest. A net force (which always points in the same direction) is applied to the object so that the *power* of the net force is constant. As the object gains speed,

- A. the magnitude of the net force remains constant.
- B. the magnitude of the net force increases.
- C. the magnitude of the net force decreases.
- D. not enough information given to decide

## A6.10

An object is initially at rest. A net force (which always points in the same direction) is applied to the object so that the *power* of the net force is constant. As the object gains speed,

- A. the magnitude of the net force remains constant.
- B. the magnitude of the net force increases.
-  C. the magnitude of the net force decreases.
- D. not enough information given to decide