

### Q4.3

The graph to the right shows the velocity of an object as a function of time as it moves along the  $x$ -axis. Which of the graphs below best shows the net force versus time for this object?

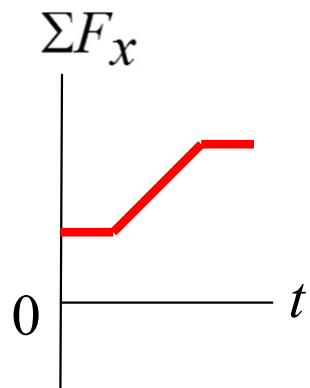

A.

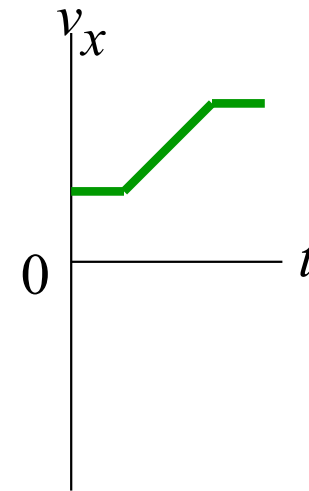
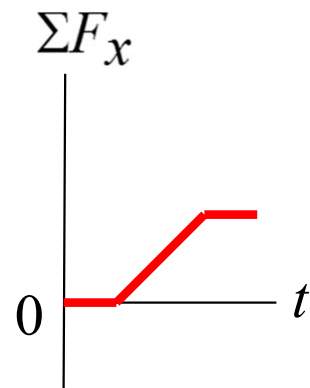

B.

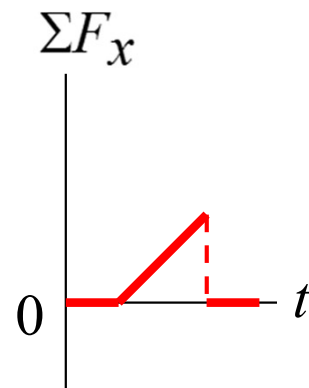

C.

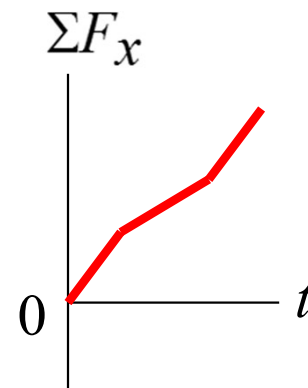

D.

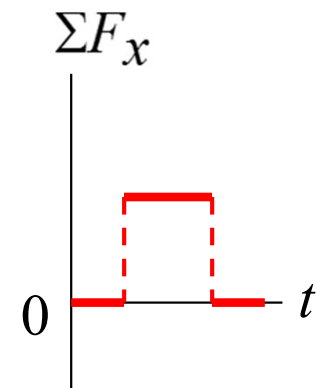

E.

# A4.3

The graph to the right shows the velocity of an object as a function of time as it moves along the  $x$ -axis. Which of the graphs below best shows the net force versus time for this object?

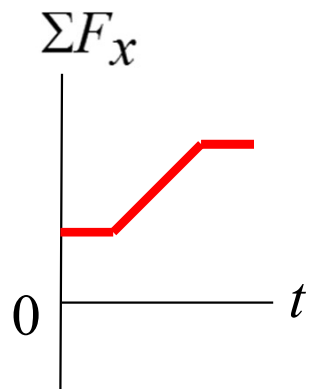
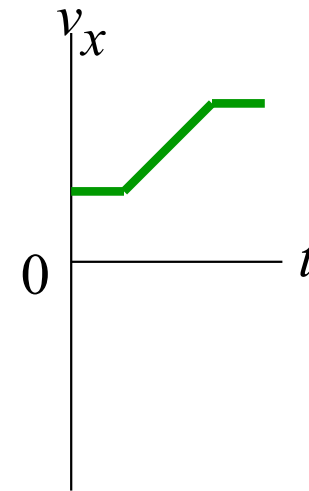

A.

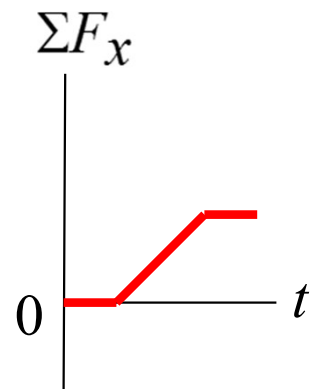

B.

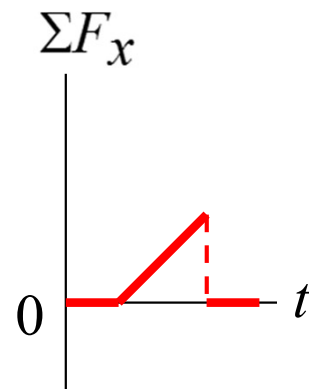

C.

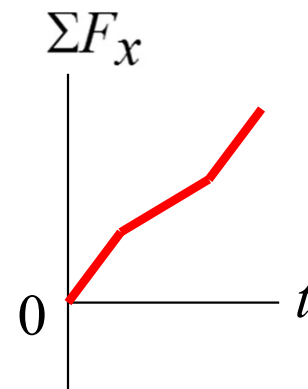

D.

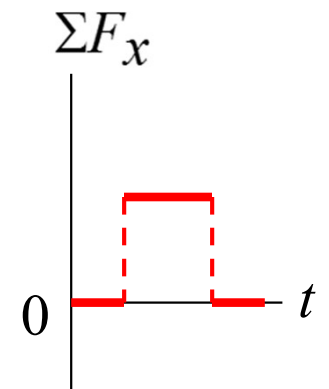

E.

## Q4.1

An elevator is being lifted at a constant speed by a steel cable attached to an electric motor. There is no air resistance, nor is there any friction between the elevator and the walls of the elevator shaft. The upward force exerted on the elevator by the cable is

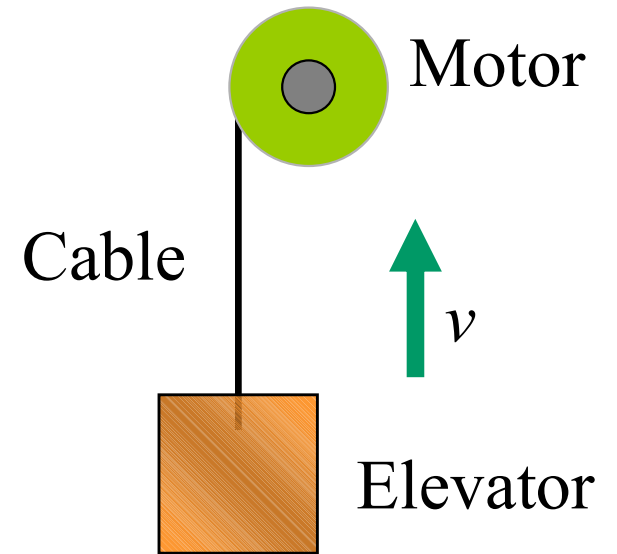

- A. greater than the downward force of gravity.
- B. equal to the force of gravity.
- C. less than the force of gravity.
- D. any of the above, depending on the speed of the elevator.
- E. any of the above, depending on the acceleration of the elevator.

## A4.1

An elevator is being lifted at a constant speed by a steel cable attached to an electric motor. There is no air resistance, nor is there any friction between the elevator and the walls of the elevator shaft. The upward force exerted on the elevator by the cable is

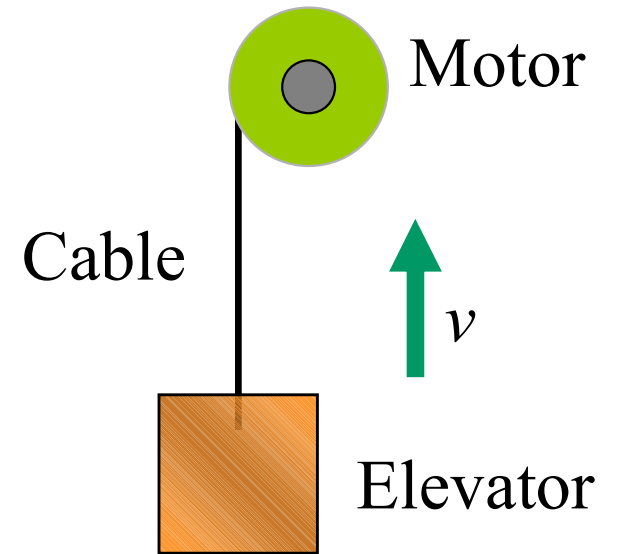

- A. greater than the downward force of gravity.
- B. equal to the force of gravity.
- C. less than the force of gravity.
- D. any of the above, depending on the speed of the elevator.
- E. any of the above, depending on the acceleration of the elevator.

## Q4.2

An elevator is being lowered at a constant speed by a steel cable attached to an electric motor. There is no air resistance, nor is there any friction between the elevator and the walls of the elevator shaft. The upward force exerted on the elevator by the cable is

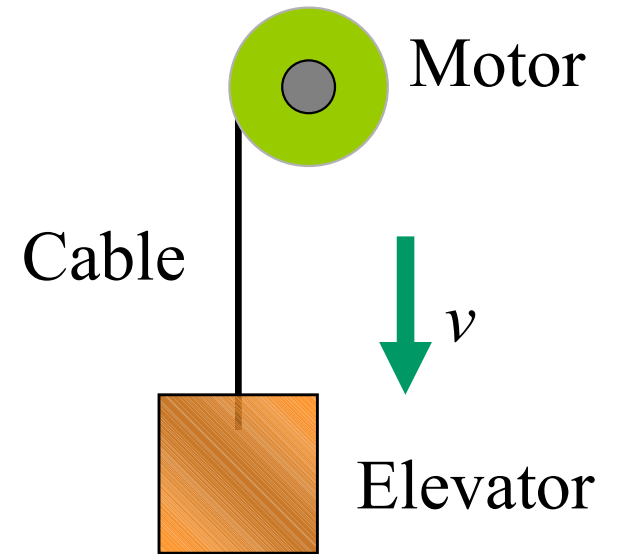

- A. greater than the downward force of gravity.
- B. equal to the force of gravity.
- C. less than the force of gravity.
- D. any of the above, depending on the speed of the elevator.
- E. any of the above, depending on the acceleration of the elevator.

## A4.2

An elevator is being lowered at a constant speed by a steel cable attached to an electric motor. There is no air resistance, nor is there any friction between the elevator and the walls of the elevator shaft. The upward force exerted on the elevator by the cable is

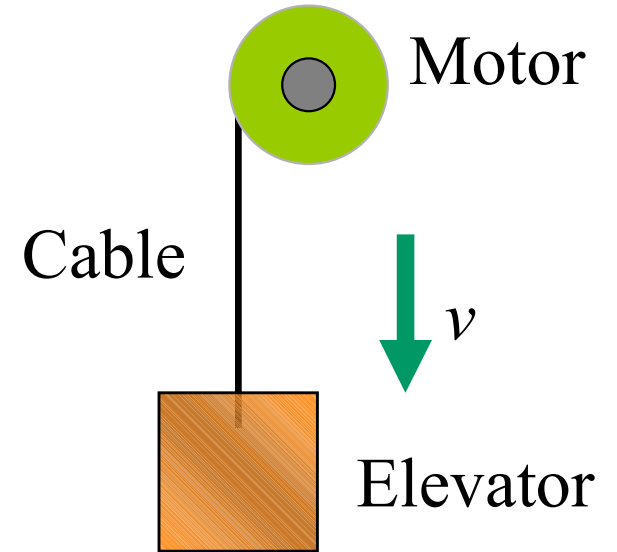

A. greater than the downward force of gravity.



B. equal to the force of gravity.

C. less than the force of gravity.

D. any of the above, depending on the speed of the elevator.

E. any of the above, depending on the acceleration of the elevator.

## Q4.4

A horse is hitched to a wagon. Which statement is correct?

- A. The force that the horse exerts on the wagon is greater than the force that the wagon exerts on the horse.
- B. The force that the horse exerts on the wagon is less than the force that the wagon exerts on the horse.
- C. The force that the horse exerts on the wagon is just as strong as the force that the wagon exerts on the horse.
- D. The answer depends on the velocity of the horse and wagon.
- E. The answer depends on the acceleration of the horse and wagon.

## A4.4

A horse is hitched to a wagon. Which statement is correct?

- A. The force that the horse exerts on the wagon is greater than the force that the wagon exerts on the horse.
- B. The force that the horse exerts on the wagon is less than the force that the wagon exerts on the horse.
-  C. The force that the horse exerts on the wagon is just as strong as the force that the wagon exerts on the horse.
- D. The answer depends on the velocity of the horse and wagon.
- E. The answer depends on the acceleration of the horse and wagon.



## Q4.5

A lightweight crate ( $A$ ) and a heavy crate ( $B$ ) are side-by-side on a horizontal floor. You apply a horizontal force  $F$  to crate  $A$ . There is friction between the crates and the floor. If the two crates are *accelerating to the right*,

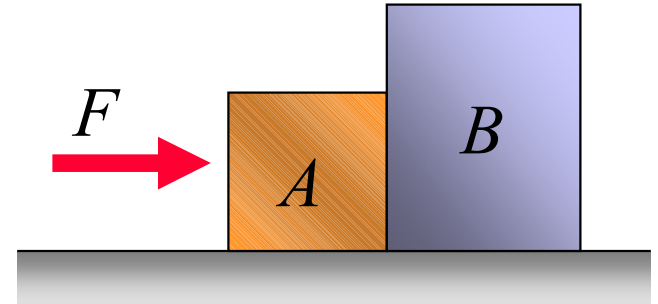

- A. crate  $A$  exerts more force on crate  $B$  than  $B$  exerts on  $A$ .
- B. crate  $A$  exerts less force on crate  $B$  than  $B$  exerts on  $A$ .
- C. crate  $A$  exerts as much force on crate  $B$  as  $B$  exerts on  $A$ .
- D. answer depends on the details of the friction force.
- E. answer depends on the magnitude of the acceleration.

## A4.5

A lightweight crate ( $A$ ) and a heavy crate ( $B$ ) are side-by-side on a horizontal floor. You apply a horizontal force  $F$  to crate  $A$ . There is friction between the crates and the floor. If the two crates are *accelerating to the right*,

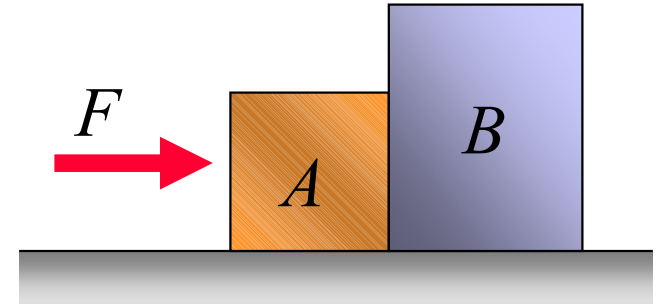

- A. crate  $A$  exerts more force on crate  $B$  than  $B$  exerts on  $A$ .
- B. crate  $A$  exerts less force on crate  $B$  than  $B$  exerts on  $A$ .
- C. crate  $A$  exerts as much force on crate  $B$  as  $B$  exerts on  $A$ .
- D. answer depends on the details of the friction force.
- E. answer depends on the magnitude of the acceleration.

## Q4.6

An elevator is being lowered at constant speed by a steel cable attached to an electric motor. There is no air resistance, nor is there any friction between the elevator and the walls of the elevator shaft. *Why* does the upward force exerted on the elevator by the cable have the same magnitude as the downward force of gravity on the elevator?

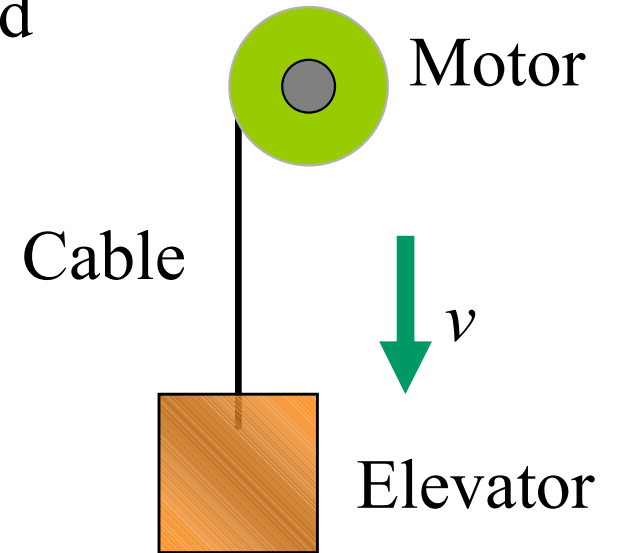

- A. Newton's first law
- B. Newton's second law
- C. Newton's third law
- D. two of A, B, and C
- E. all three of A, B, and C

## A4.6

An elevator is being lowered at constant speed by a steel cable attached to an electric motor. There is no air resistance, nor is there any friction between the elevator and the walls of the elevator shaft. *Why* does the upward force exerted on the elevator by the cable have the same magnitude as the downward force of gravity on the elevator?

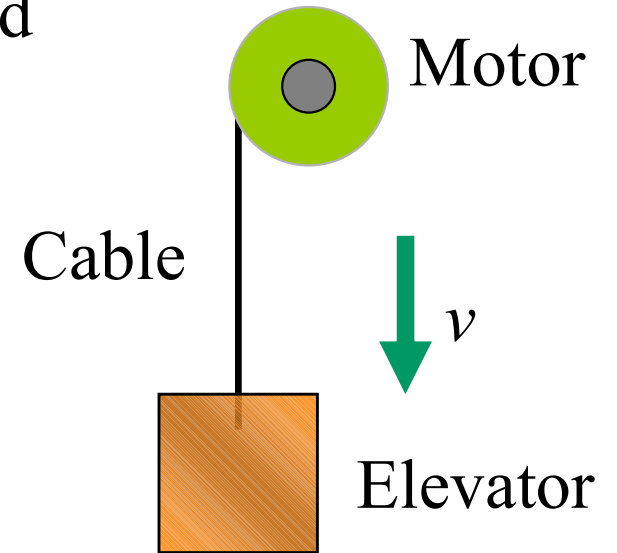

- A. Newton's first law
- B. Newton's second law
- C. Newton's third law
- D. two of A, B, and C
- E. all three of A, B, and C

## Q4.7

A lightweight crate ( $A$ ) and a heavy crate ( $B$ ) are side-by-side on a frictionless horizontal surface. You apply a horizontal force  $F$  to crate  $A$ , causing  $A$  and  $B$  to accelerate together to the right. How do the magnitudes of the following forces compare: (i) the force  $F$ , (ii) the net force on  $A$ , and (iii) the net force on  $B$ ?

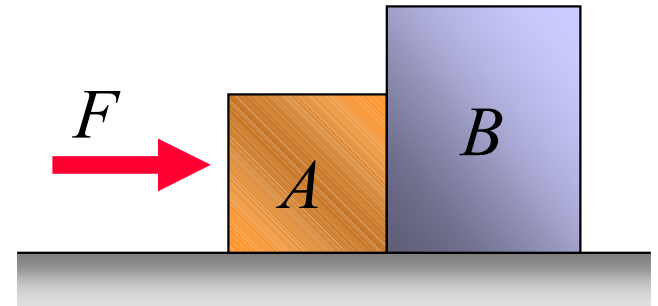

- A.  $F = \text{net force on } A = \text{net force on } B$
- B.  $F > \text{net force on } A = \text{net force on } B$
- C.  $F > \text{net force on } A > \text{net force on } B$
- D.  $F > \text{net force on } B > \text{net force on } A$
- E. none of the above

## A4.7

A lightweight crate ( $A$ ) and a heavy crate ( $B$ ) are side-by-side on a frictionless horizontal surface. You apply a horizontal force  $F$  to crate  $A$ , causing  $A$  and  $B$  to accelerate together to the right. How do the magnitudes of the following forces compare: (i) the force  $F$ , (ii) the net force on  $A$ , and (iii) the net force on  $B$ ?

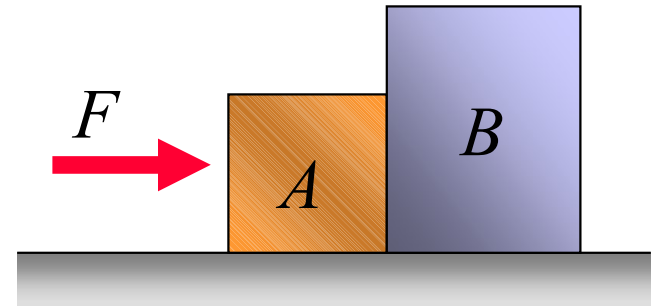

A.  $F = \text{net force on } A = \text{net force on } B$

B.  $F > \text{net force on } A = \text{net force on } B$

C.  $F > \text{net force on } A > \text{net force on } B$

D.  $F > \text{net force on } B > \text{net force on } A$

E. none of the above

## Q4.8

A lightweight crate ( $A$ ) and a heavy crate ( $B$ ) are side-by-side on a frictionless horizontal surface. If you apply a horizontal force  $F$  to crate  $A$ ,

- A. the acceleration is greater than if  $B$  were on the left and  $A$  were on the right.
- B. the acceleration is less than if  $B$  were on the left and  $A$  were on the right.
- C. the crates will not move if  $F$  is less than the combined weight of  $A$  and  $B$ .
- D. two of the above are correct.
- E. none of the above is correct.

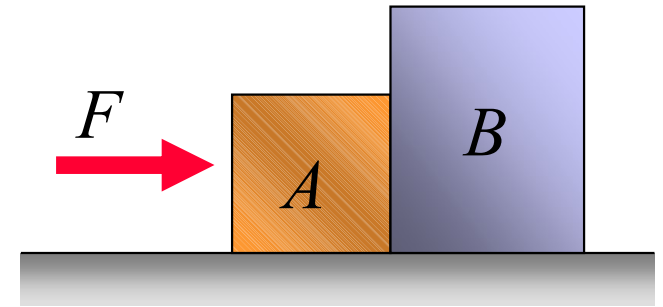

## A4.8

A lightweight crate ( $A$ ) and a heavy crate ( $B$ ) are side-by-side on a frictionless horizontal surface. If you apply a horizontal force  $F$  to crate  $A$ ,

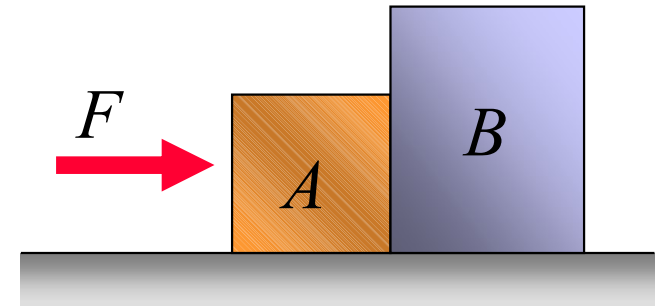

- A. the acceleration is greater than if  $B$  were on the left and  $A$  were on the right.
- B. the acceleration is less than if  $B$  were on the left and  $A$  were on the right.
- C. the crates will not move if  $F$  is less than the combined weight of  $A$  and  $B$ .
- D. two of the above are correct.
- E. none of the above is correct.



## Q4.9

You are standing at rest and begin to walk forward. What force pushes you forward?

- A. the force of your feet on the ground
- B. the force of your acceleration
- C. the force of your velocity
- D. the force of your momentum
- E. the force of the ground on your feet

## A4.9

You are standing at rest and begin to walk forward. What force pushes you forward?

A. the force of your feet on the ground

B. the force of your acceleration

C. the force of your velocity

D. the force of your momentum

 E. the force of the ground on your feet

## Q4.10

A person pulls horizontally on block  $B$ , causing both blocks to move horizontally as a unit. There is friction between block  $B$  and the horizontal table. If the two blocks are moving to the right at constant velocity,

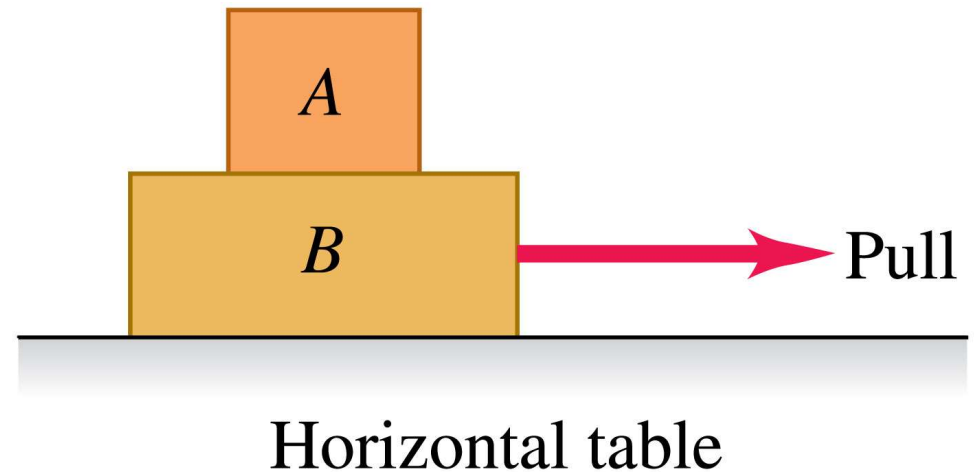

- A. the horizontal force that  $B$  exerts on  $A$  points to the left.
- B. the horizontal force that  $B$  exerts on  $A$  points to the right.
- C.  $B$  exerts no horizontal force on  $A$ .
- D. answer depends on the strength of the pull.
- E. answer depends on the strength of the pull and the masses of the blocks.

## A4.10

A person pulls horizontally on block  $B$ , causing both blocks to move horizontally as a unit. There is friction between block  $B$  and the horizontal table. If the two blocks are moving to the right at constant velocity,

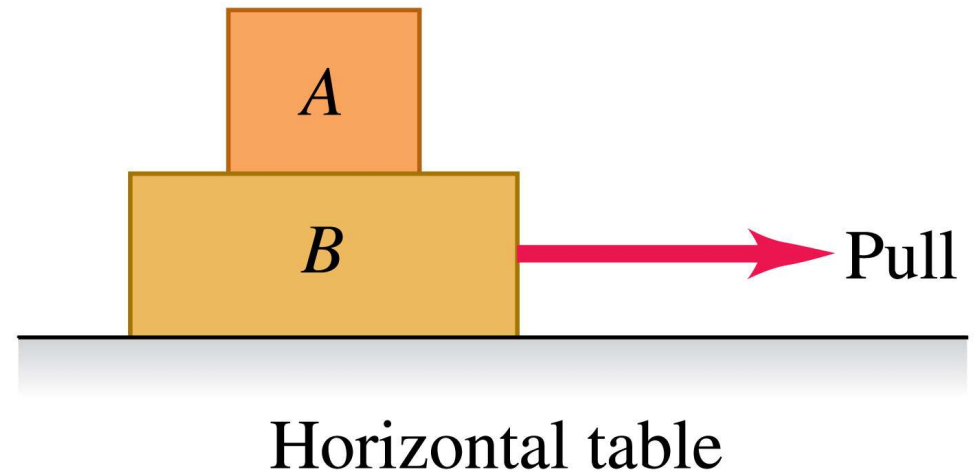

- A. the horizontal force that  $B$  exerts on  $A$  points to the left.
- B. the horizontal force that  $B$  exerts on  $A$  points to the right.
- C.  $B$  exerts no horizontal force on  $A$ .
- D. answer depends on the strength of the pull.
- E. answer depends on the strength of the pull and the masses of the blocks.

## Q4.11

A ball sits at rest on a horizontal tabletop. According to Newton's third law, by itself ( $\vec{F}_{A \text{ on } B} = -\vec{F}_{B \text{ on } A}$ ), the weight of the ball has the same magnitude as

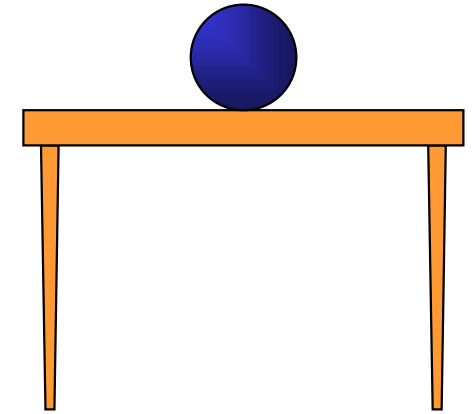

- A. the downward force of the ball on the table.
- B. the upward force of the table on the ball.
- C. the upward force that the ball exerts on planet earth.
- D. two of A, B, and C.
- E. all of A, B, and C.

## A4.11

A ball sits at rest on a horizontal tabletop. According to Newton's third law, by itself ( $\vec{F}_{A \text{ on } B} = -\vec{F}_{B \text{ on } A}$ ), the weight of the ball has the same magnitude as

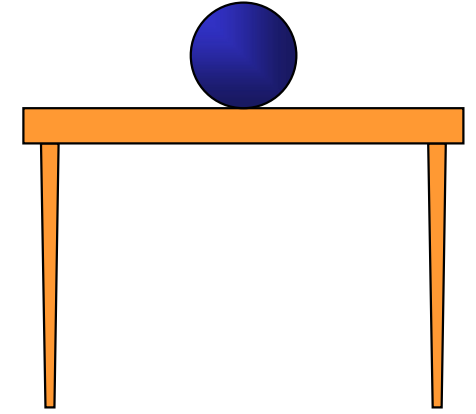

- A. the downward force of the ball on the table.
- B. the upward force of the table on the ball.
- C. the upward force that the ball exerts on planet earth.
- D. two of A, B, and C.
- E. all of A, B, and C.

## Q4.12

A ball sits at rest on a horizontal tabletop. The weight of the ball is equal to the magnitude of the upward force that the tabletop exerts on the ball. Why?

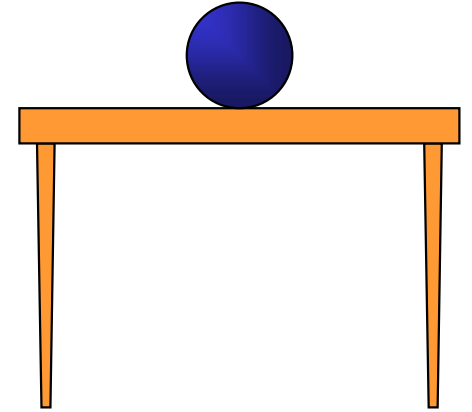

- A. This is a consequence of Newton's first law.
- B. This is a consequence of Newton's third law.
- C. We assume that the table top is perfectly rigid.
- D. Two of the above three statements are correct.
- E. All of the first three statements are correct.

## A4.12

A ball sits at rest on a horizontal tabletop. The weight of the ball is equal to the magnitude of the upward force that the tabletop exerts on the ball. Why?

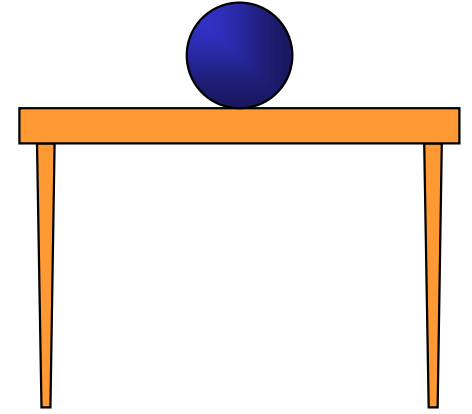

- A. This is a consequence of Newton's first law.
- B. This is a consequence of Newton's third law.
- C. We assume that the table top is perfectly rigid.
- D. Two of the above three statements are correct.
- E. All of the first three statements are correct.



## Q4.13

A woman pulls on a 6.00-kg crate, which in turn is connected to a 4.00-kg crate by a light rope. The light rope remains taut. Compared to the 6.00-kg crate, the lighter 4.00-kg crate

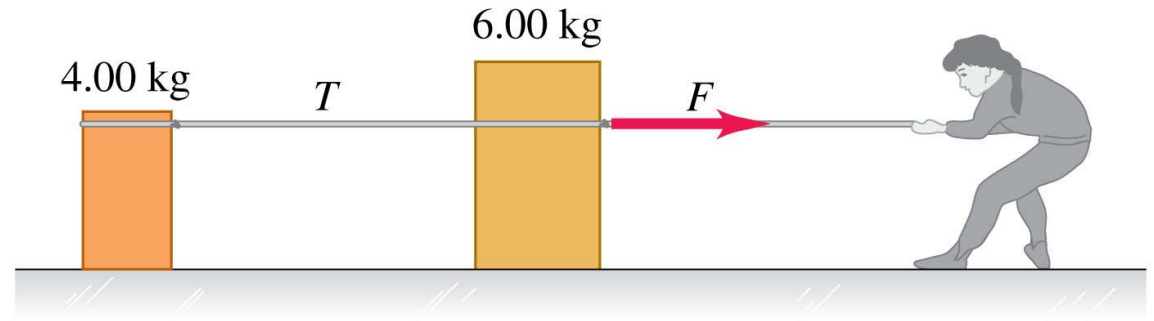

- A. is subjected to the same net force and has the same acceleration.
- B. is subjected to a smaller net force and has the same acceleration.
- C. is subjected to the same net force and has a smaller acceleration.
- D. is subjected to a smaller net force and has a smaller acceleration.
- E. is none of the above.

## A4.13

A woman pulls on a 6.00-kg crate, which in turn is connected to a 4.00-kg crate by a light rope. The light rope remains taut. Compared to the 6.00-kg crate, the lighter 4.00-kg crate

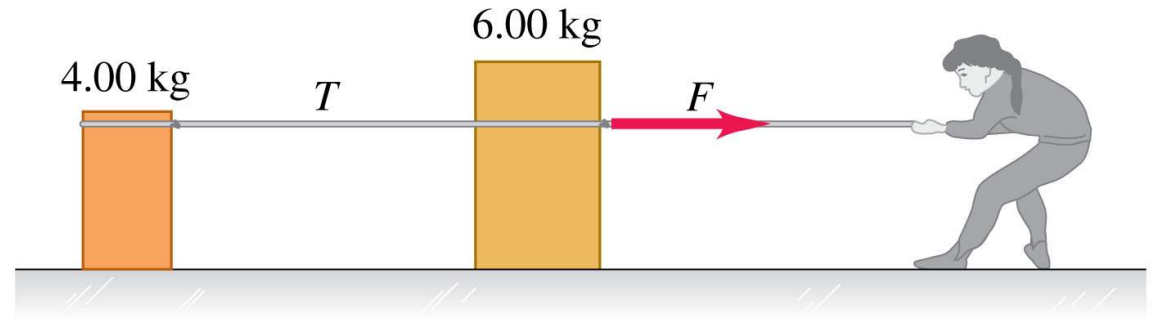

- A. is subjected to the same net force and has the same acceleration.
- ✓ B. is subjected to a smaller net force and has the same acceleration.
- C. is subjected to the same net force and has a smaller acceleration.
- D. is subjected to a smaller net force and has a smaller acceleration.
- E. is none of the above.

## Q4.14

A woman pulls on a 6.00-kg crate, which in turn is connected to a 4.00-kg crate by a light rope. The light rope remains taut. If the two crates *move to the right at constant speed*, which is greater: the force that the 6.00-kg crate exerts on the 4.00-kg crate, or the force that the 4.00-kg crate exerts on the 6.00-kg crate?

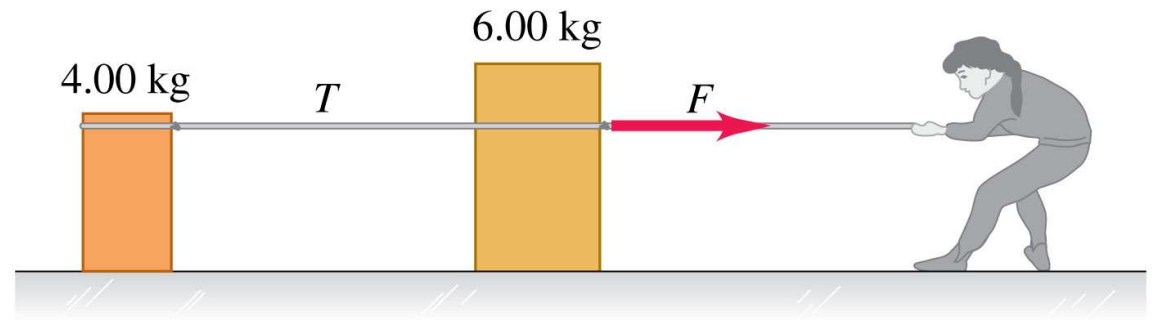

If the two crates *move to the right at constant speed*, which is greater: the force that the 6.00-kg crate exerts on the 4.00-kg crate, or the force that the 4.00-kg crate exerts on the 6.00-kg crate?

- A. The force of the 6.00-kg crate on the 4.00-kg crate is greater.
- B. The force of the 4.00-kg crate on the 6.00-kg crate is greater.
- C. Both forces have the same magnitude.
- D. The answer depends on the magnitude  $F$  of the pull.
- E. The answer depends on the magnitude  $F$  of the pull and the strength of the friction force on each crate.

## A4.14

A woman pulls on a 6.00-kg crate, which in turn is connected to a 4.00-kg crate by a light rope. The light rope remains taut. If the two crates *move to the right at constant speed*, which is greater: the force that the 6.00-kg crate exerts on the 4.00-kg crate, or the force that the 4.00-kg crate exerts on the 6.00-kg crate?

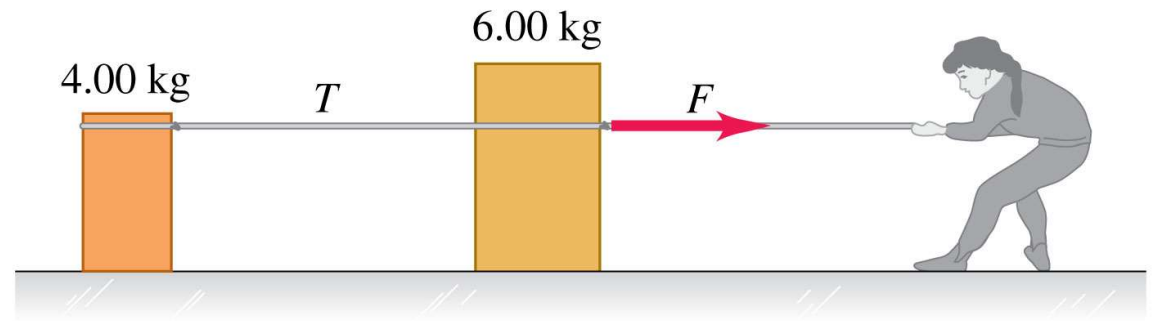

If the two crates *move to the right at constant speed*, which is greater: the force that the 6.00-kg crate exerts on the 4.00-kg crate, or the force that the 4.00-kg crate exerts on the 6.00-kg crate?

- A. The force of the 6.00-kg crate on the 4.00-kg crate is greater.
- B. The force of the 4.00-kg crate on the 6.00-kg crate is greater.
- C. Both forces have the same magnitude.
- D. The answer depends on the magnitude  $F$  of the pull.
- E. The answer depends on the magnitude  $F$  of the pull and the strength of the friction force on each crate.

## Q4.15

A woman pulls on a 6.00-kg crate, which in turn is connected to a 4.00-kg crate by a light rope. The light rope remains taut. If the two crates *are*

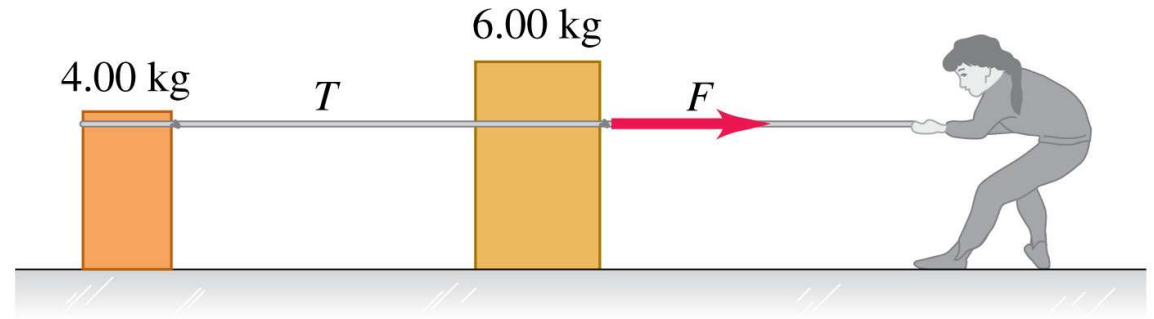

*accelerating to the right*, which is greater: the force that the 6.00-kg crate exerts on the 4.00-kg crate, or the force that the 4.00-kg crate exerts on the 6.00-kg crate?

- A. The force of the 6.00-kg crate on the 4.00-kg crate is greater.
- B. The force of the 4.00-kg crate on the 6.00-kg crate is greater.
- C. Both forces have the same magnitude.
- D. The answer depends on the magnitude  $F$  of the pull.
- E. The answer depends on the magnitude  $F$  of the pull and the strength of the friction force on each crate.

## A4.15

A woman pulls on a 6.00-kg crate, which in turn is connected to a 4.00-kg crate by a light rope.

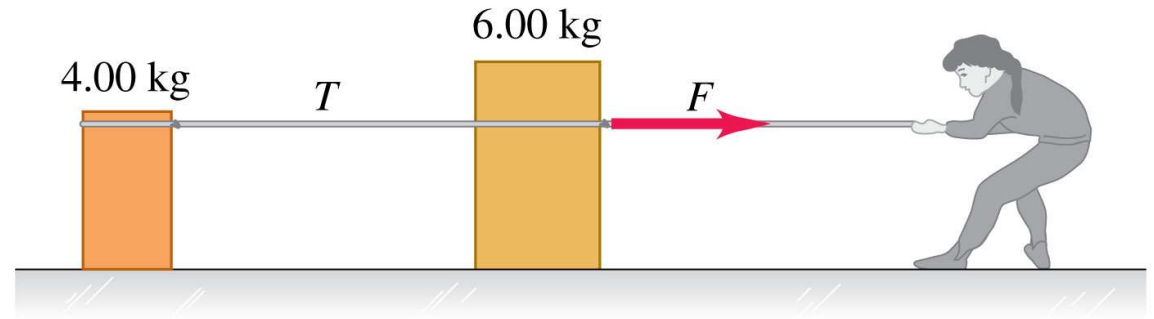

The light rope remains taut. If the two crates *are accelerating to the right*, which is greater: the force that the 6.00-kg crate exerts on the 4.00-kg crate, or the force that the 4.00-kg crate exerts on the 6.00-kg crate?

- A. The force of the 6.00-kg crate on the 4.00-kg crate is greater.
- B. The force of the 4.00-kg crate on the 6.00-kg crate is greater.
- C. Both forces have the same magnitude.
- D. The answer depends on the magnitude  $F$  of the pull.
- E. The answer depends on the magnitude  $F$  of the pull and the strength of the friction force on each crate.

## Q4.16

You push a 1.00-kg food tray through the cafeteria line with a constant 9.0-N force. The tray in turn pushes on a 0.50-kg milk carton. If the food tray and milk carton *move to the left at constant speed*, which is

greater in magnitude: the force that the food tray exerts on the milk carton, or the force that the milk carton exerts on the food tray?

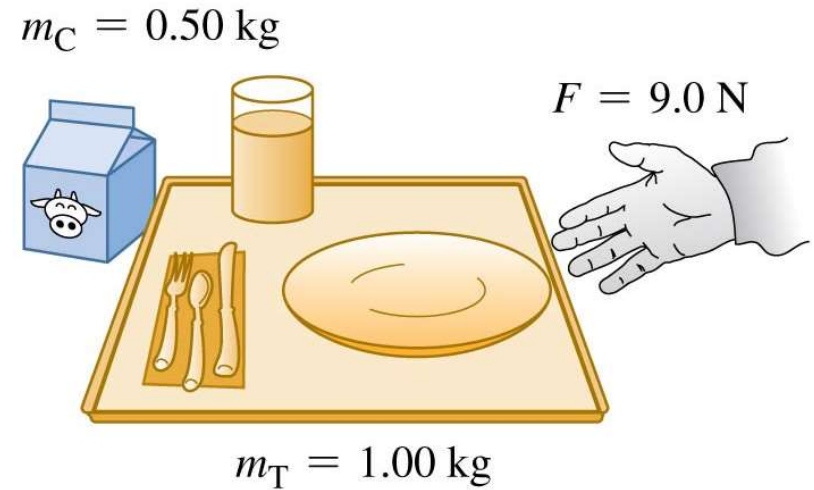

- A. The force of the food tray on the milk carton is greater.
- B. The force of the milk carton on the food tray is greater,
- C. Both forces have the same magnitude.
- D. Either A or B, depending on the speed.
- E. Either A, B, or C, depending on the speed.

## A4.16

You push a 1.00-kg food tray through the cafeteria line with a constant 9.0-N force. The tray in turn pushes on a 0.50-kg milk carton. If the food tray and milk carton *move to the left at constant speed*, which is

greater in magnitude: the force that the food tray exerts on the milk carton, or the force that the milk carton exerts on the food tray?

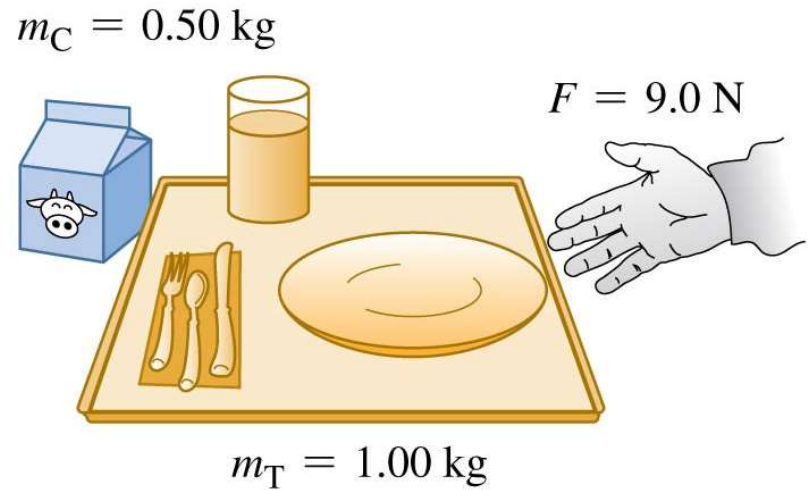

- A. The force of the food tray on the milk carton is greater.
- B. The force of the milk carton on the food tray is greater,
- C. Both forces have the same magnitude.
- D. Either A or B, depending on the speed.
- E. Either A, B, or C, depending on the speed.



## Q4.17

You push a 1.00-kg food tray through the cafeteria line with a constant 9.0-N force. The tray in turn pushes on a 0.50-kg milk carton. If the food tray and milk carton *accelerate to the left*, which is greater in magnitude: the force that the food tray exerts on the milk carton, or the force that the milk carton exerts on the food tray?

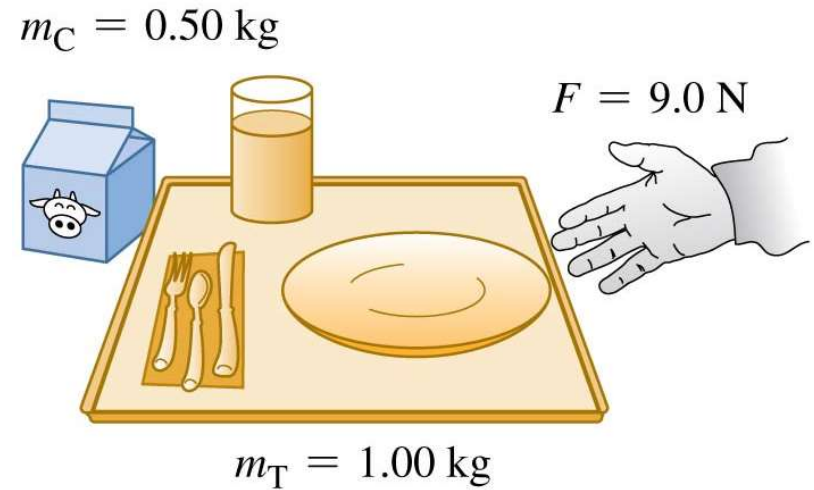

- A. The force of the food tray on the milk carton is greater.
- B. The force of the milk carton on the food tray is greater.
- C. Both forces have the same magnitude.
- D. Either A or B, depending on the acceleration.
- E. Either A, B, or C, depending on the acceleration.

## A4.17

You push a 1.00-kg food tray through the cafeteria line with a constant 9.0-N force. The tray in turn pushes on a 0.50-kg milk carton. If the food tray and milk carton *accelerate to the left*, which is greater in magnitude: the force that the food tray exerts on the milk carton, or the force that the milk carton exerts on the food tray?

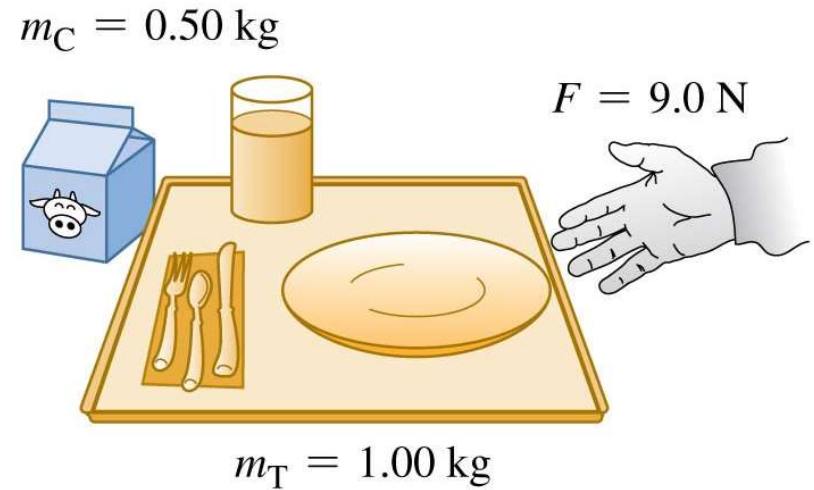

- A. The force of the food tray on the milk carton is greater.
- B. The force of the milk carton on the food tray is greater.
- C. Both forces have the same magnitude.
- D. Either A or B, depending on the acceleration.
- E. Either A, B, or C, depending on the acceleration.

## Q-RT4.1

When you apply an upward force of magnitude  $F$  to a block of mass  $2.00\text{ kg}$ , the block accelerates upward at  $3.00\text{ m/s}^2$ . You can ignore any forces exerted on the block by the air. **Rank the following forces** in order of their magnitude, from largest to smallest.

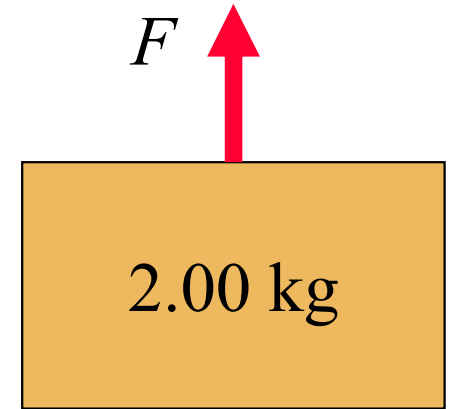

- A. force  $F$
- B. the net force on the block
- C. the gravitational force on the block

## A-RT4.1

When you apply an upward force of magnitude  $F$  to a block of mass  $2.00\text{ kg}$ , the block accelerates upward at  $3.00\text{ m/s}^2$ . You can ignore any forces exerted on the block by the air. **Rank the following forces** in order of their magnitude, from largest to smallest.

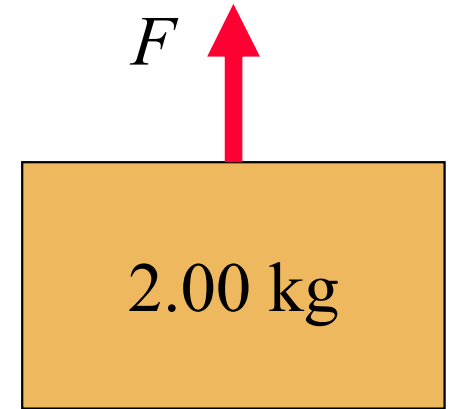

- A. force  $F$
- B. the net force on the block
- C. the gravitational force on the block

 **Answer: ACB**

EOC 4.4: A man is dragging a trunk up the loading ramp of a mover's truck as shown. How large a force  $|\vec{F}|$  is necessary for the component  $F_x$  parallel to the ramp to be 60 N?

- $60 / \cos 20^\circ$
- $60 / \cos 30^\circ$
- $60 / \cos 50^\circ$
- $60 / \sin 50^\circ$
- $60 / \tan 50^\circ$

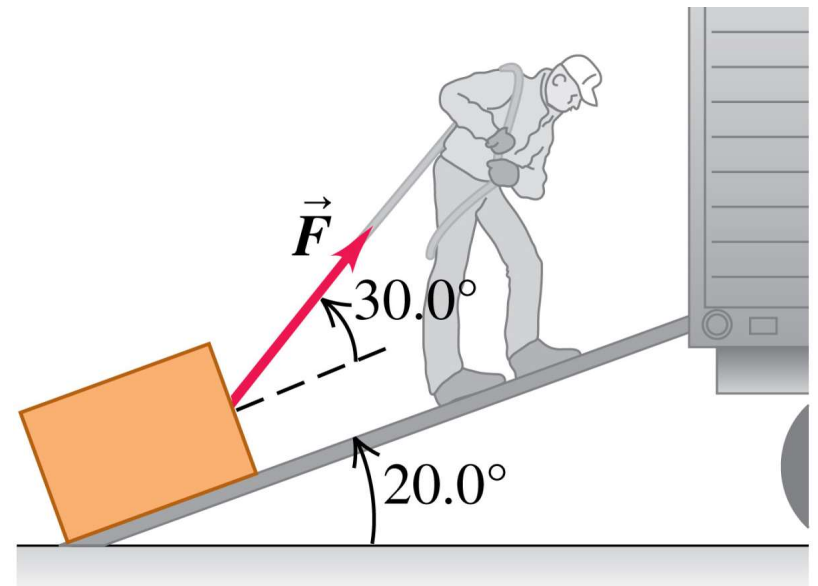

Measured weight of a person accelerating upwards in an elevator

- Higher than  $W$
- Lower than  $W$
- Same as  $W$

Puck  $A$  has  $2 \times$  the mass of puck  $B$ . Both are at rest at  $t = 0$  when a force  $\vec{F}$  is applied to both of them. If puck  $A$  goes a distance  $x_A$  in a time  $t$ , puck  $B$  will go a distance  $x_B$  in the same time, where

\_\_\_\_\_.

a)  $x_B = \frac{1}{4} x_A$

b)  $x_B = \frac{1}{2} x_A$

c)  $x_B = x_A$

d)  $x_B = 2x_A$

e)  $x_B = 4x_A$

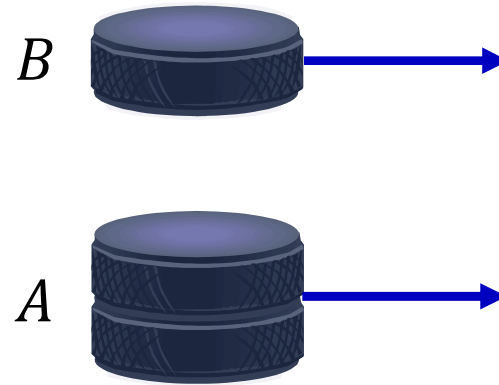

A hanging flowerpot: Draw a FBD for each flower basket, and calculate the tension in each cable. The weights of the three pots are  $w_A = 200\text{ N}$ ,  $w_B = 100\text{ N}$  and  $w_C = 500\text{ N}$ .

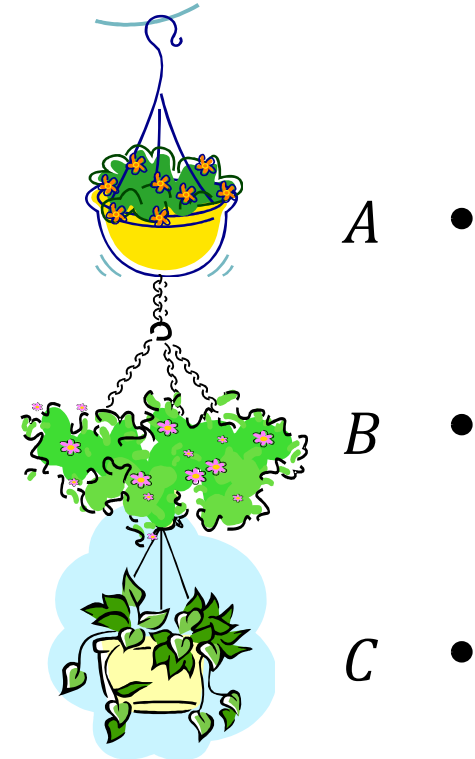

- $T_A = 200\text{ N}, T_B = 100\text{ N}, T_C = 500\text{ N}$
- $T_A = 200\text{ N}, T_B = 300\text{ N}, T_C = 800\text{ N}$
- $T_A = 800\text{ N}, T_B = 300\text{ N}, T_C = 200\text{ N}$
- $T_A = 800\text{ N}, T_B = 600\text{ N}, T_C = 500\text{ N}$
- $T_A = 800\text{ N}, T_B = 800\text{ N}, T_C = 800\text{ N}$



A cart (weight  $w_1$ ) is attached by a lightweight cable to a bucket (weight  $w_2$ ) as shown. The ramp is frictionless. When released, the cart accelerates up the ramp. Which is a correct FBD?

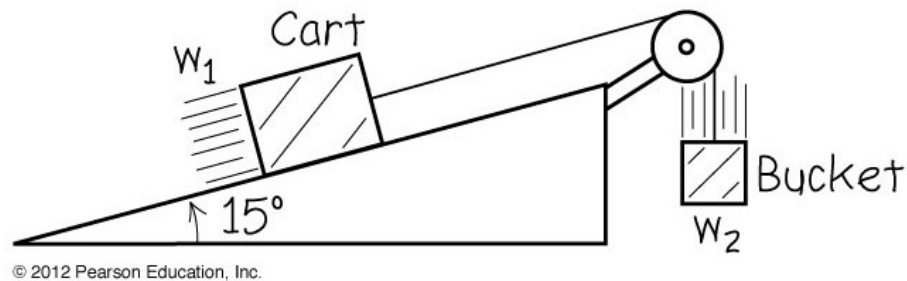

- © 2012 Pearson Education, Inc.
- a)
- b)
- c)
- d)

A cart (weight  $w_1$ ) is attached by a lightweight cable to a bucket (weight  $w_2$ ) as shown. The ramp is frictionless. When released, the cart accelerates up the ramp. How does the cable tension  $T$  compare to  $w_2$ ?

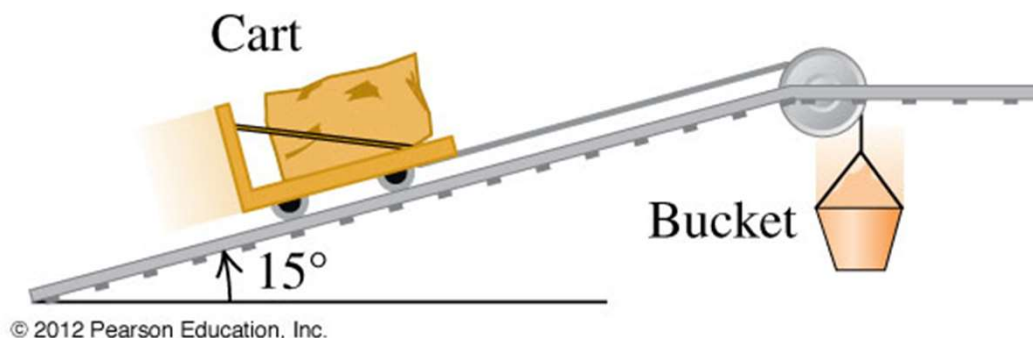

- a)  $T = w_2$
- b)  $T > w_2$
- c)  $T < w_2$
- d) Not enough information given to decide

You are pushing a 1.00-kg food tray through the cafeteria line with a constant 9.0-N force. As the tray moves, the glass of mass  $m_G$  on the tray moves without slipping due to friction. Which of the following statements are true?

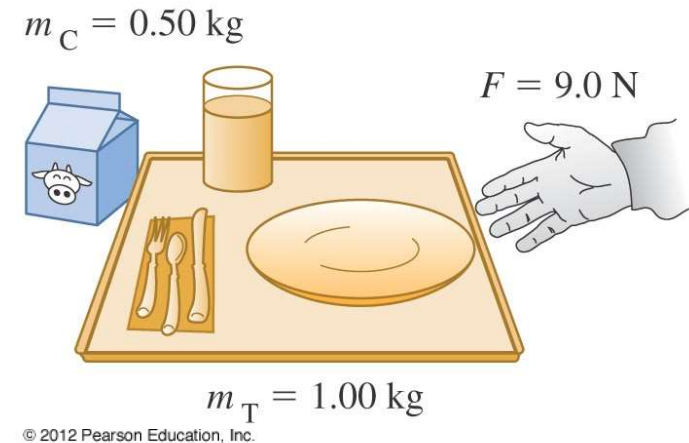

- a) The friction acting on the glass is equal to  $\mu_s m_G g$
- b) The friction acting on the glass is less than  $\mu_s m_G g$
- c) The friction acting on the glass is  $\leq \mu_s m_G g$
- d) The friction acting on the glass is equal to  $\mu_k m_G g$
- e) The friction acting on the glass is less than  $\mu_k m_G g$

Back to an earlier example: If the coefficient of static and kinetic frictions are 0.75 and 0.50 respectively, what force,  $\vec{F}$ , is required to keep the boxes moving at 5.00 m/s?

- 75 N
- 100 N
- 125 N
- 150 N ✓
- 250 N

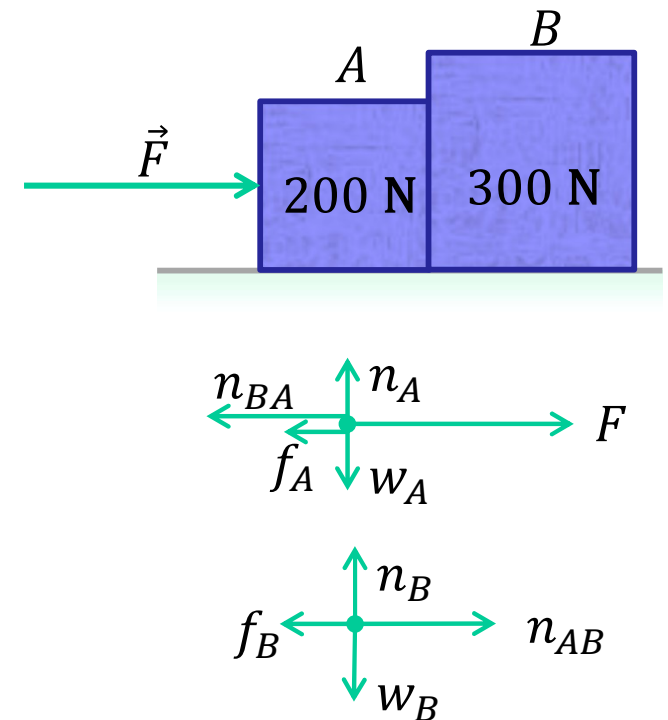

A sled moves on essentially frictionless ice. It is attached by a rope to a vertical post set in the ice. Once given a push, the sled moves around the post at constant speed in a circle of radius  $R$ . If the rope breaks,

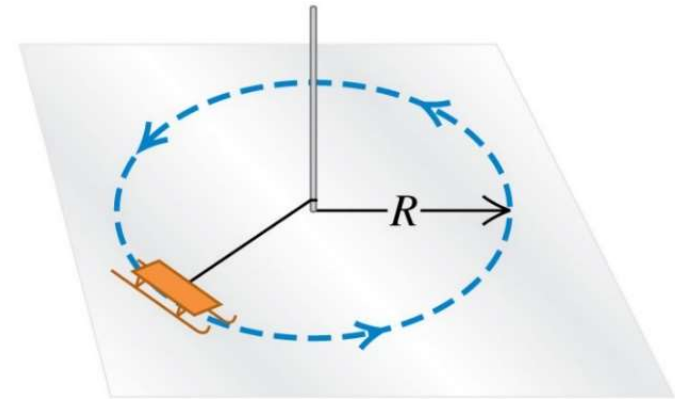

© 2012 Pearson Education, Inc.

- a) the sled will keep moving in a circle
- b) the sled will move on a curved path, but not a circle
- c) the sled will follow a curved path for a while, then move in a straight line ✓
- d) the sled will move in a straight line

A pendulum bob of mass  $m$  is attached to the ceiling by a thin wire of length  $L$ . The bob moves at constant speed in a horizontal circle of radius  $R$ , with the wire making a constant angle  $\beta$  with the vertical. The tension in the wire



- a) is greater than  $mg$
- b) is equal to  $mg$
- c) is less than  $mg$
- d) is any of the above, depending on the speed of the bob,  $v$

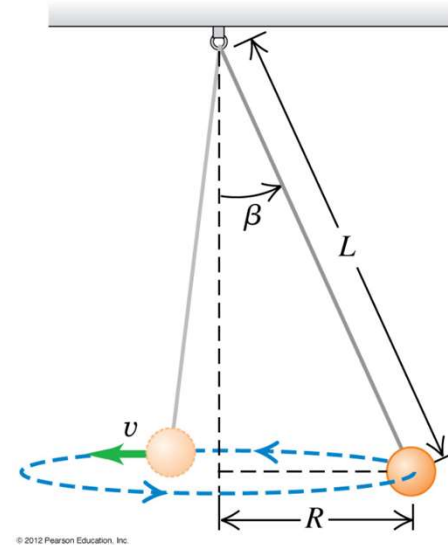

## EOC 5.97 (●●●)

How many action/reaction pairs are there between the three bodies shown ( $A$ ,  $B$  and  $S$ )?

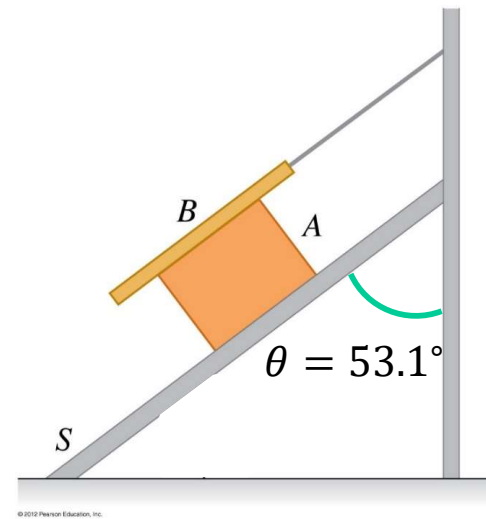

- a) 1
- b) 2
- c) 3 ✓
- d) 4
- e) more than 4