

## Q10.1

The four forces shown all have the same magnitude:  $F_1 = F_2 = F_3 = F_4$ .

Which force produces the *greatest torque* about the point  $O$  (marked by the blue dot)?

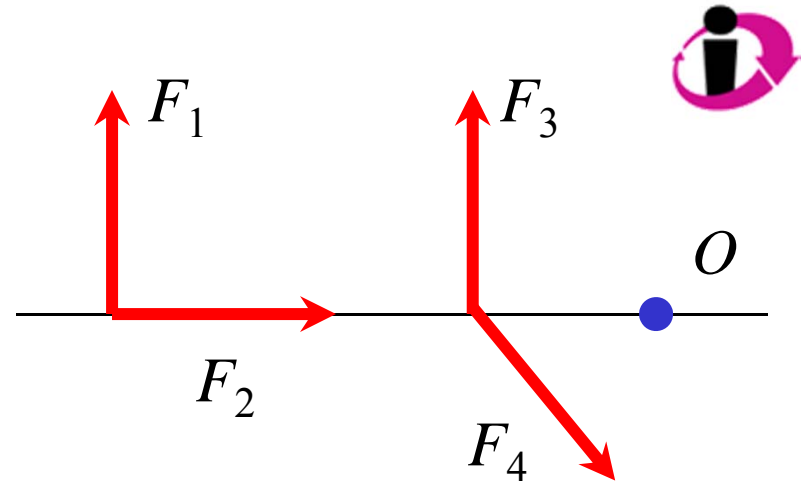

- A.  $F_1$
- B.  $F_2$
- C.  $F_3$
- D.  $F_4$
- E. not enough information given to decide

## A10.1

The four forces shown all have the same magnitude:  $F_1 = F_2 = F_3 = F_4$ .

Which force produces the *greatest torque* about the point  $O$  (marked by the blue dot)?

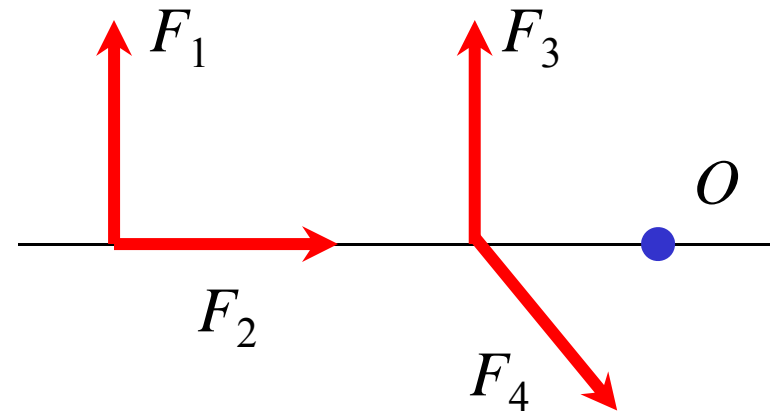

- ✓ A.  $F_1$
- B.  $F_2$
- C.  $F_3$
- D.  $F_4$
- E. not enough information given to decide

## Q10.2

Which of the four forces shown here produces a torque about  $O$  that is directed *out* of the plane of the drawing?

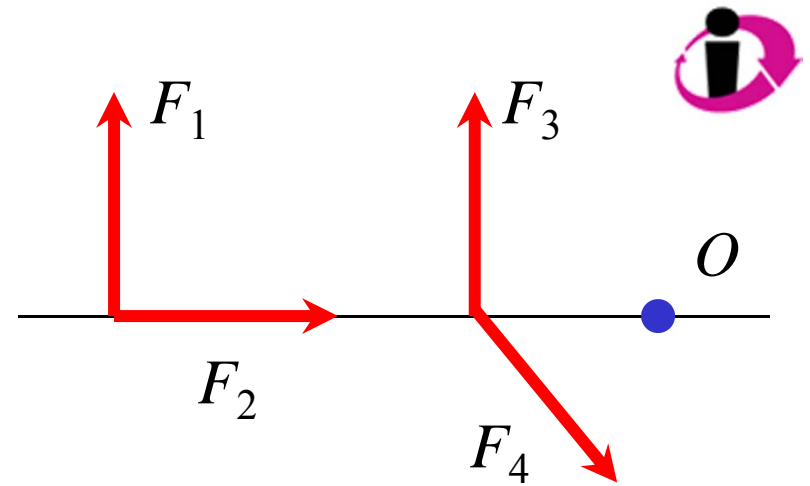

- A.  $F_1$
- B.  $F_2$
- C.  $F_3$
- D.  $F_4$
- E. more than one of these

A10.2

Which of the four forces shown here produces a torque about  $O$  that is directed *out* of the plane of the drawing?

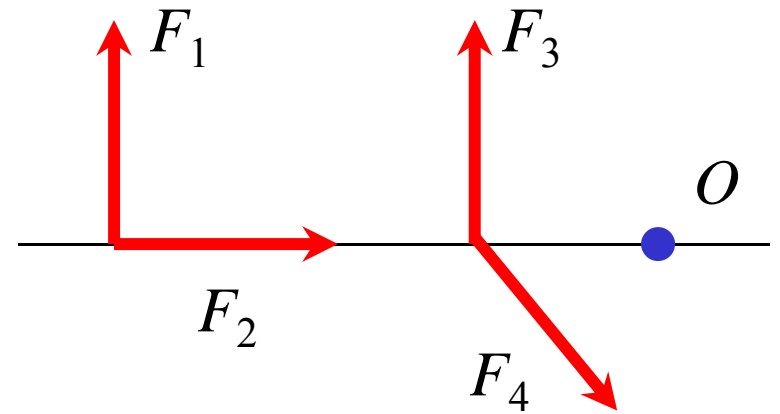

- A.  $F_1$
- B.  $F_2$
- C.  $F_3$
- ✓ D.  $F_4$
- E. more than one of these

### Q10.3



A plumber pushes straight down on the end of a long wrench as shown. What is the magnitude of the torque he applies about the pipe at lower right?

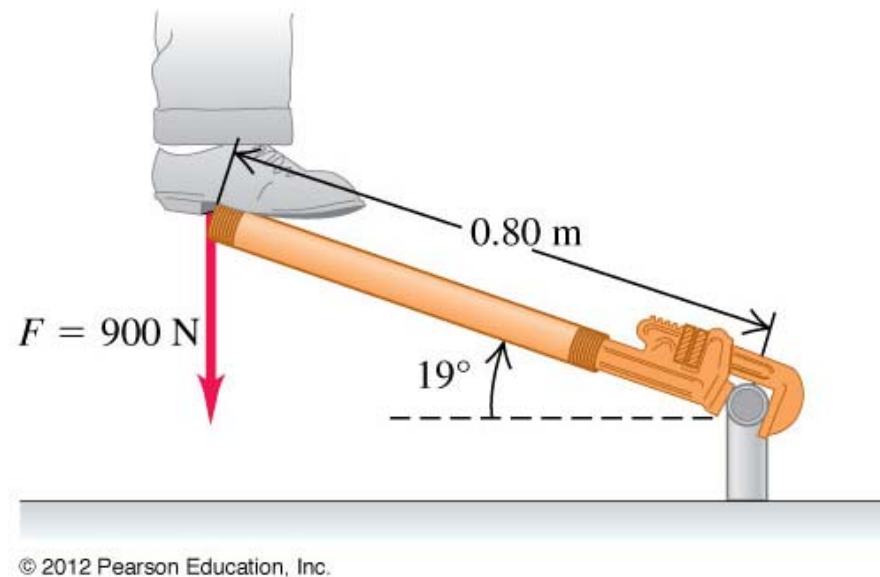

- A.  $(0.80 \text{ m})(900 \text{ N})\sin 19^\circ$
- B.  $(0.80 \text{ m})(900 \text{ N})\cos 19^\circ$
- C.  $(0.80 \text{ m})(900 \text{ N})\tan 19^\circ$
- D. none of the above

## A10.3

A plumber pushes straight down on the end of a long wrench as shown. What is the magnitude of the torque he applies about the pipe at lower right?

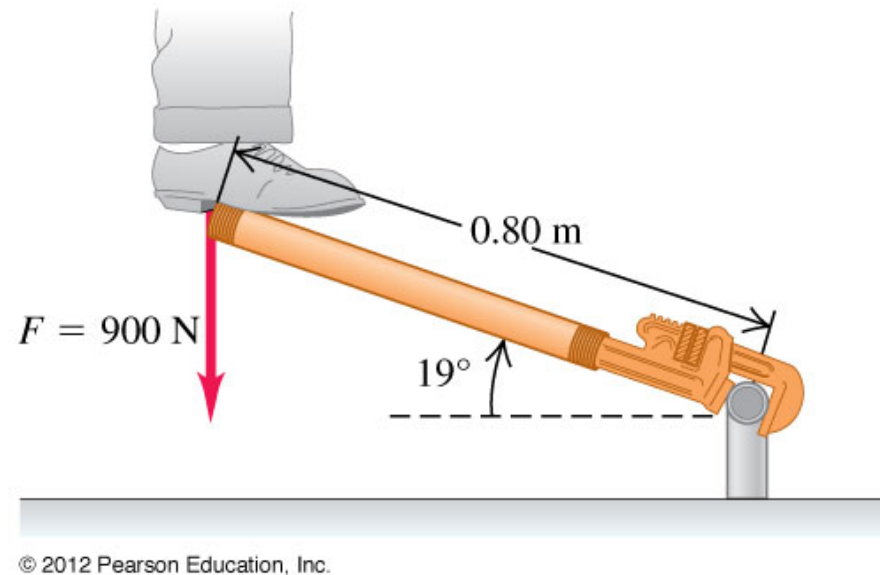

- A.  $(0.80 \text{ m})(900 \text{ N})\sin 19^\circ$
- ✓ B.  $(0.80 \text{ m})(900 \text{ N})\cos 19^\circ$
- C.  $(0.80 \text{ m})(900 \text{ N})\tan 19^\circ$
- D. none of the above

## Q10.4



A force  $\vec{F} = (4\hat{i} + 3\hat{j})\text{N}$  acts on an object at a point located at the position  $\vec{r} = (6\hat{k})\text{m}$ .

What is the torque that this force applies about the origin?

- A. zero
- B.  $(24\hat{i} + 18\hat{j})\text{N}\cdot\text{m}$
- C.  $(-24\hat{i} - 18\hat{j})\text{N}\cdot\text{m}$
- D.  $(-18\hat{i} + 24\hat{j})\text{N}\cdot\text{m}$
- E.  $(-18\hat{i} - 24\hat{j})\text{N}\cdot\text{m}$

## A10.4

A force  $\vec{F} = (4\hat{i} + 3\hat{j})\text{N}$  acts on an object at a point located at the position  $\vec{r} = (6\hat{k})\text{m}$ .

What is the torque that this force applies about the origin?

- A. zero
- B.  $(24\hat{i} + 18\hat{j})\text{N}\cdot\text{m}$
- C.  $(-24\hat{i} - 18\hat{j})\text{N}\cdot\text{m}$
-  D.  $(-18\hat{i} + 24\hat{j})\text{N}\cdot\text{m}$
- E.  $(-18\hat{i} - 24\hat{j})\text{N}\cdot\text{m}$



## Q10.5



A glider of mass  $m_1$  on a frictionless horizontal track is connected to an object of mass  $m_2$  by a massless string. The glider accelerates to the right, the object accelerates downward, and the string rotates the pulley. What is the relationship among  $T_1$  (the tension in the horizontal part of the string),  $T_2$  (the tension in the vertical part of the string), and the weight  $m_2g$  of the object?

A.  $m_2g = T_2 = T_1$

B.  $m_2g > T_2 = T_1$

C.  $m_2g > T_2 > T_1$

D.  $m_2g = T_2 > T_1$

E. none of the above

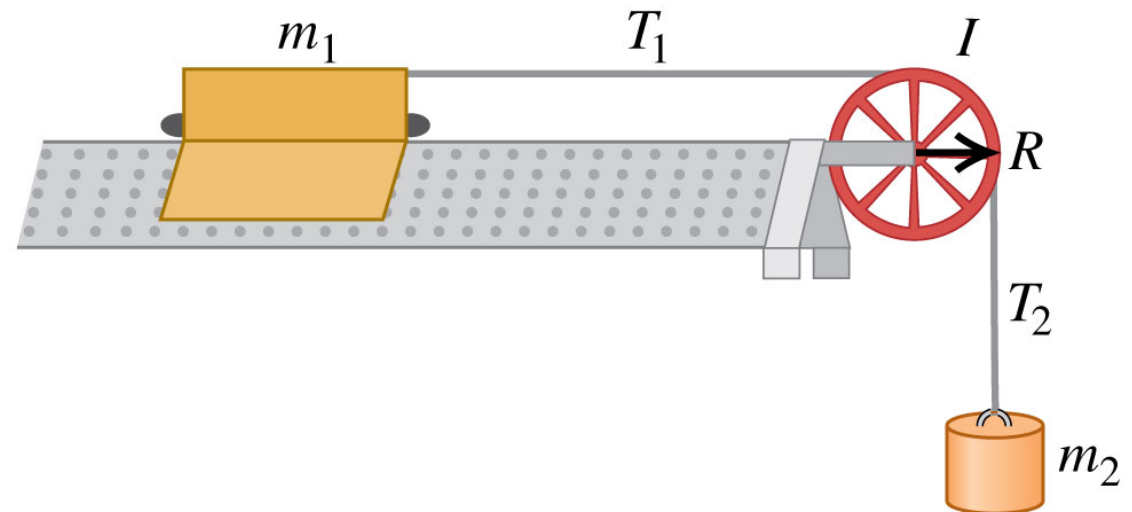

© 2012 Pearson Education, Inc.

## A10.5

A glider of mass  $m_1$  on a frictionless horizontal track is connected to an object of mass  $m_2$  by a massless string. The glider accelerates to the right, the object accelerates downward, and the string rotates the pulley. What is the relationship among  $T_1$  (the tension in the horizontal part of the string),  $T_2$  (the tension in the vertical part of the string), and the weight  $m_2g$  of the object?

- A.  $m_2g = T_2 = T_1$
- B.  $m_2g > T_2 = T_1$
- ✓ C.  $m_2g > T_2 > T_1$
- D.  $m_2g = T_2 > T_1$
- E. none of the above

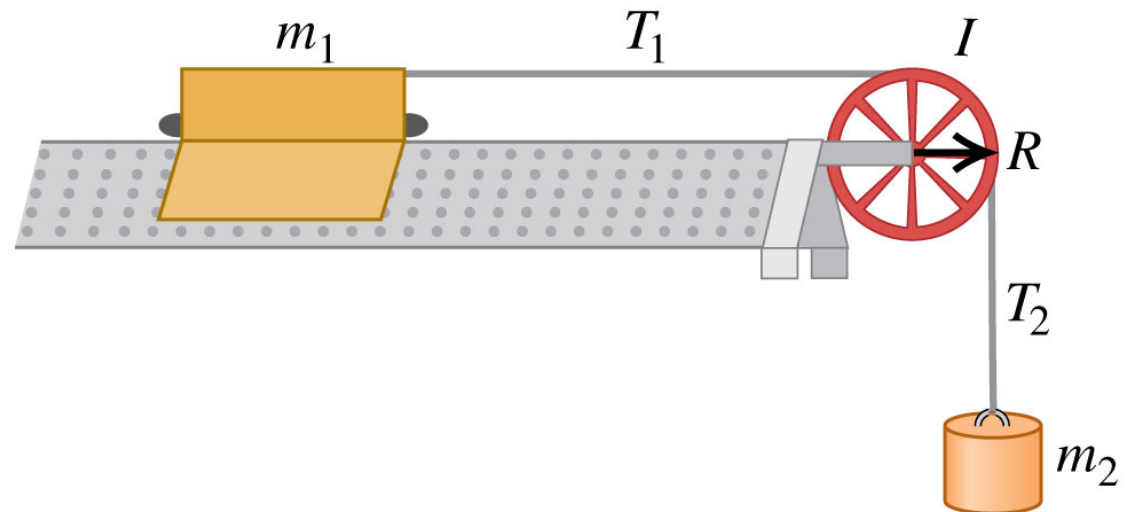

© 2012 Pearson Education, Inc.

## Q10.6



A lightweight string is wrapped several times around the rim of a small hoop. If the free end of the string is held in place and the hoop is released from rest, the string unwinds and the hoop descends. How does the tension in the string ( $T$ ) compare to the weight of the hoop ( $w$ )?

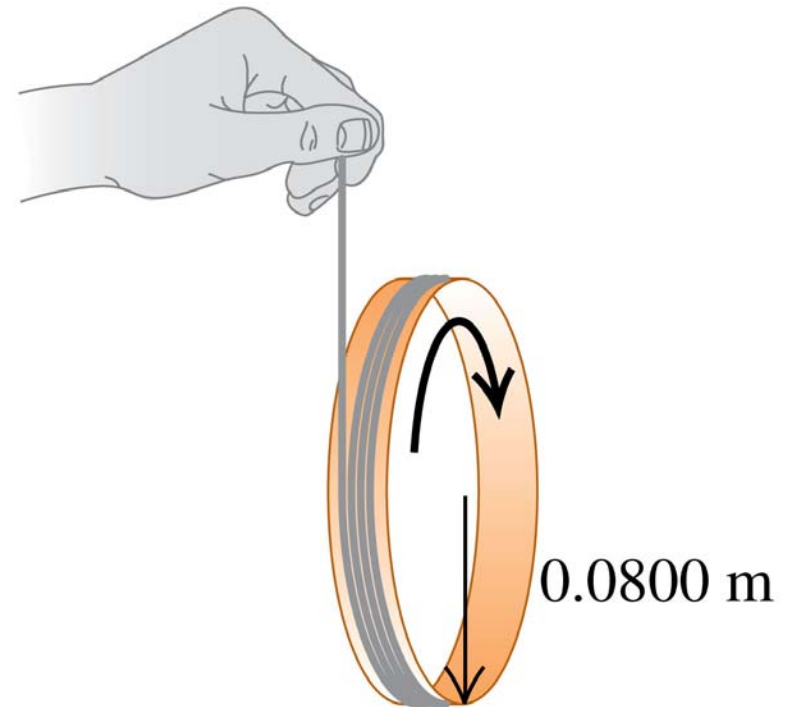

- A.  $T = w$
- B.  $T > w$
- C.  $T < w$
- D. not enough information given to decide

## A10.6

A lightweight string is wrapped several times around the rim of a small hoop. If the free end of the string is held in place and the hoop is released from rest, the string unwinds and the hoop descends. How does the tension in the string ( $T$ ) compare to the weight of the hoop ( $w$ )?

- A.  $T = w$
- B.  $T > w$
- C.  $T < w$
- D. not enough information given to decide

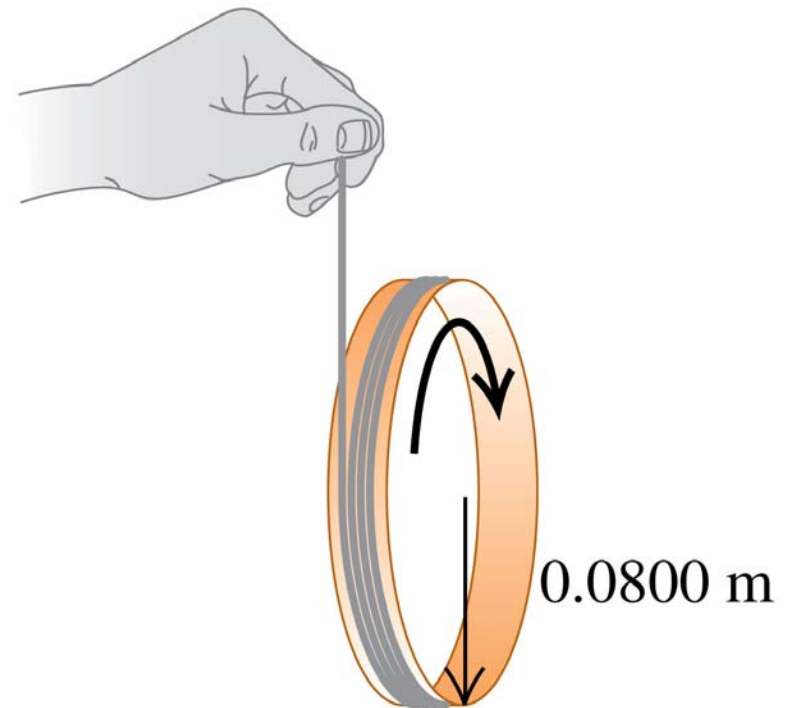

## Q10.7



A solid bowling ball rolls down a ramp.

Which of the following forces exerts a torque on the bowling ball about its center?

- A. the weight of the ball
- B. the normal force exerted by the ramp
- C. the friction force exerted by the ramp
- D. more than one of the above
- E. The answer depends on whether the ball rolls without slipping.

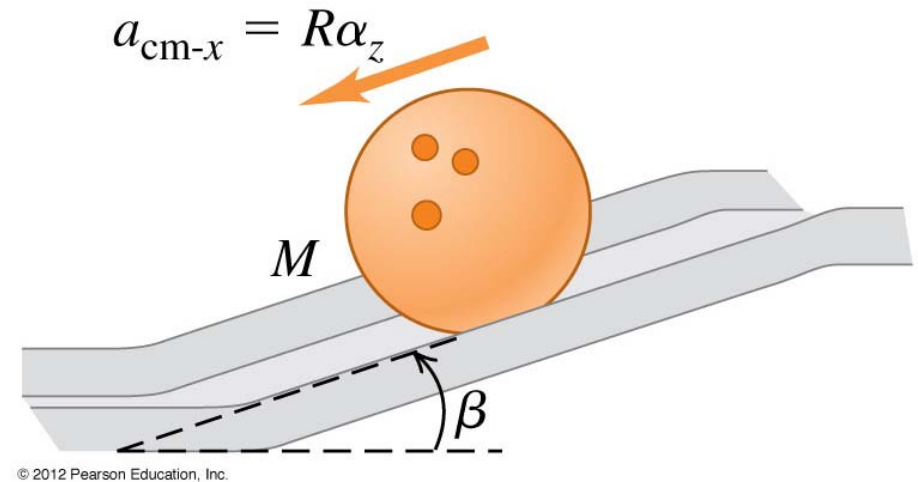

## A10.7

A solid bowling ball rolls down a ramp.

Which of the following forces exerts a torque on the bowling ball about its center?

- A. the weight of the ball
- B. the normal force exerted by the ramp
- ✓ C. the friction force exerted by the ramp
- D. more than one of the above
- E. The answer depends on whether the ball rolls without slipping.

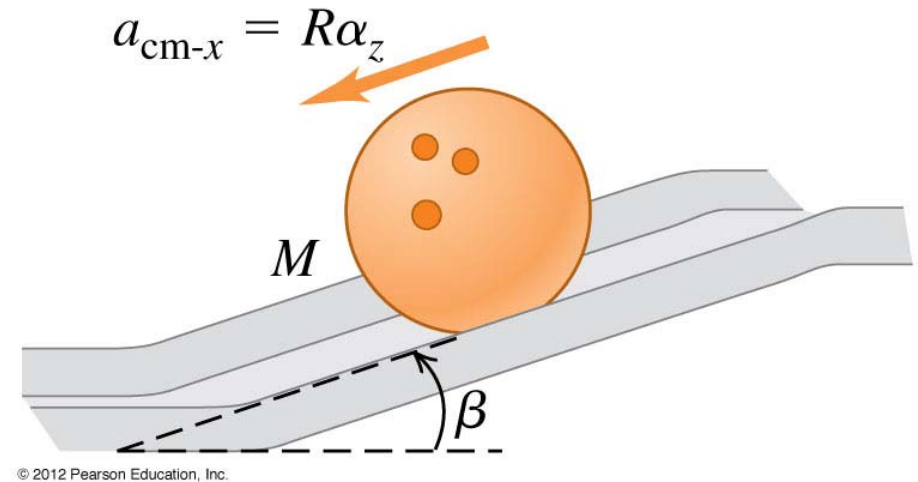

## Q10.8

A yo-yo is placed on a horizontal surface as shown. There is sufficient friction for the yo-yo to roll without slipping. If the string is pulled to the right as shown,

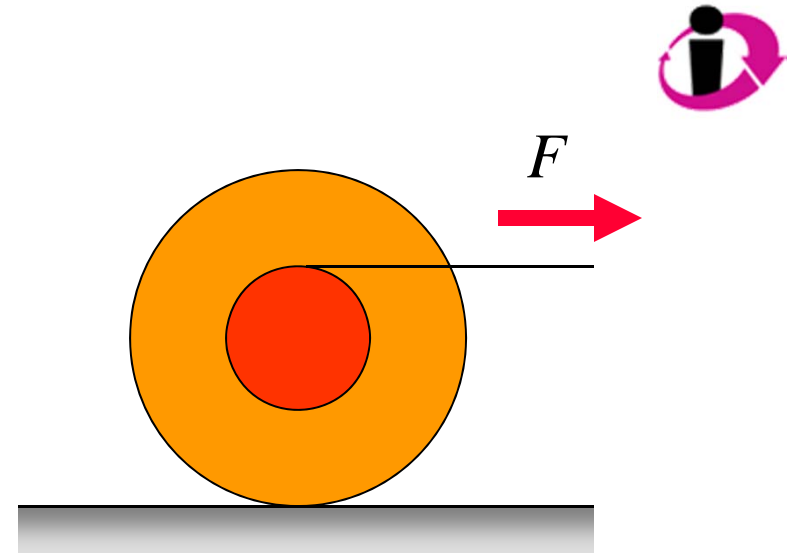

- A. the yo-yo rolls to the right.
- B. the yo-yo rolls to the left.
- C. the yo-yo remains at rest.
- D. The answer depends on the magnitude  $F$  of the pulling force compared to the magnitude of the friction force.

## A10.8

A yo-yo is placed on a horizontal surface as shown. There is sufficient friction for the yo-yo to roll without slipping. If the string is pulled to the right as shown,

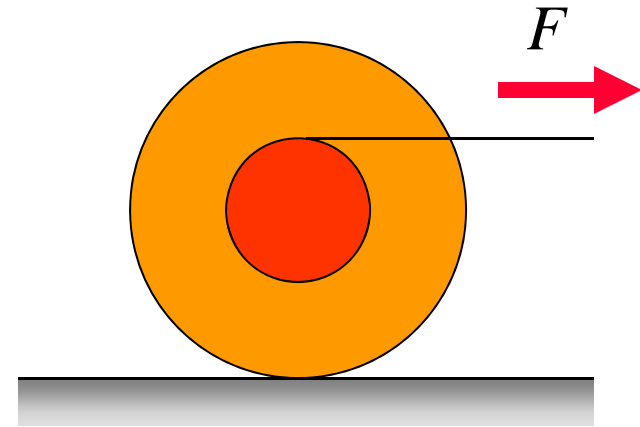

- ✓ A. the yo-yo rolls to the right.
- B. the yo-yo rolls to the left.
- C. the yo-yo remains at rest.
- D. The answer depends on the magnitude  $F$  of the pulling force compared to the magnitude of the friction force.



## Q10.9



A yo-yo is placed on a horizontal surface as shown. There is sufficient friction for the yo-yo to roll without slipping. If the string is pulled to the right as shown,

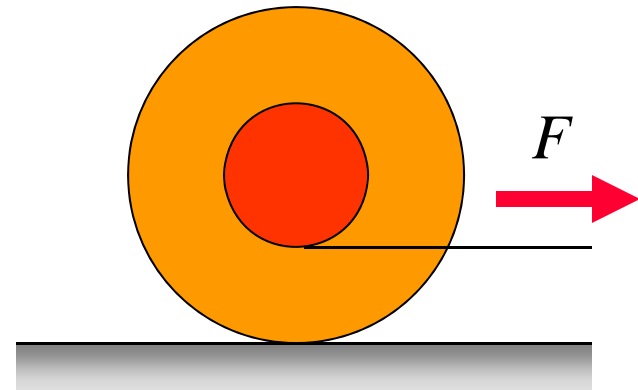

- A. the yo-yo rolls to the right.
- B. the yo-yo rolls to the left.
- C. the yo-yo remains at rest.
- D. The answer depends on the magnitude  $F$  of the pulling force compared to the magnitude of the friction force.

## A10.9

A yo-yo is placed on a horizontal surface as shown. There is sufficient friction for the yo-yo to roll without slipping. If the string is pulled to the right as shown,

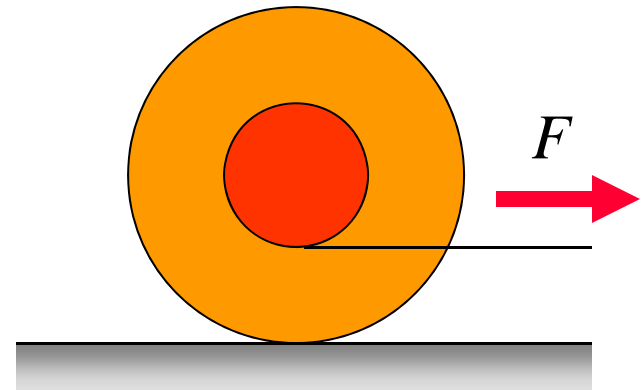

- ✓ A. the yo-yo rolls to the right.
- B. the yo-yo rolls to the left.
- C. the yo-yo remains at rest.
- D. The answer depends on the magnitude  $F$  of the pulling force compared to the magnitude of the friction force.

## Q10.10

A yo-yo is placed on a horizontal surface as shown. There is sufficient friction for the yo-yo to roll without slipping. If the string is pulled straight up as shown,

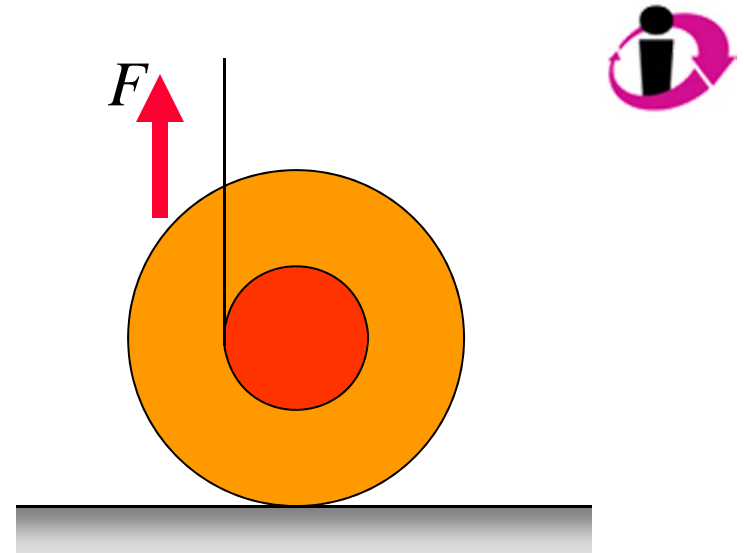

- A. the yo-yo rolls to the right.
- B. the yo-yo rolls to the left.
- C. the yo-yo remains at rest.
- D. The answer depends on the magnitude  $F$  of the pulling force compared to the magnitude of the friction force.

A10.10

A yo-yo is placed on a horizontal surface as shown. There is sufficient friction for the yo-yo to roll without slipping. If the string is pulled straight up as shown,

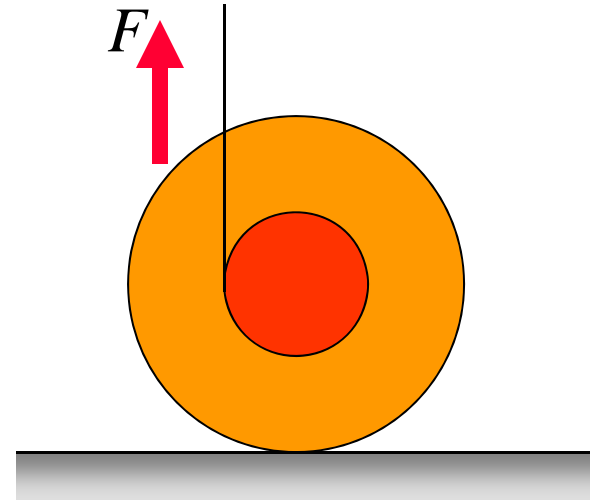

- ✓ A. the yo-yo rolls to the right.
- B. the yo-yo rolls to the left.
- C. the yo-yo remains at rest.
- D. The answer depends on the magnitude  $F$  of the pulling force compared to the magnitude of the friction force.

## Q10.11

A spinning figure skater pulls his arms in as he rotates on the ice. As he pulls his arms in, what happens to his angular momentum  $L$  and kinetic energy  $K$ ?

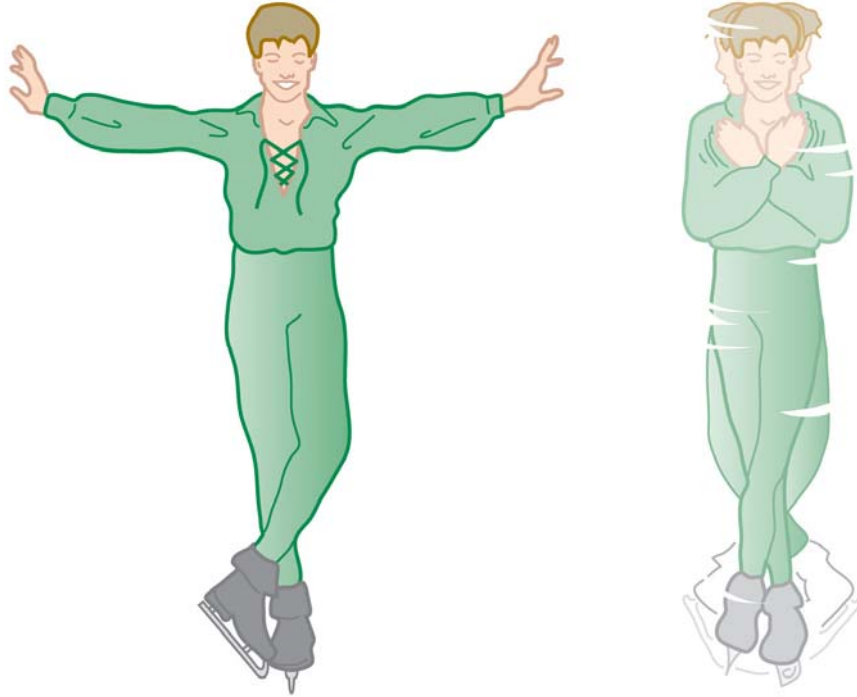

- A.  $L$  and  $K$  both increase.
- B.  $L$  stays the same;  $K$  increases.
- C.  $L$  increases;  $K$  stays the same.
- D.  $L$  and  $K$  both stay the same.

## A10.11

A spinning figure skater pulls his arms in as he rotates on the ice. As he pulls his arms in, what happens to his angular momentum  $L$  and kinetic energy  $K$ ?

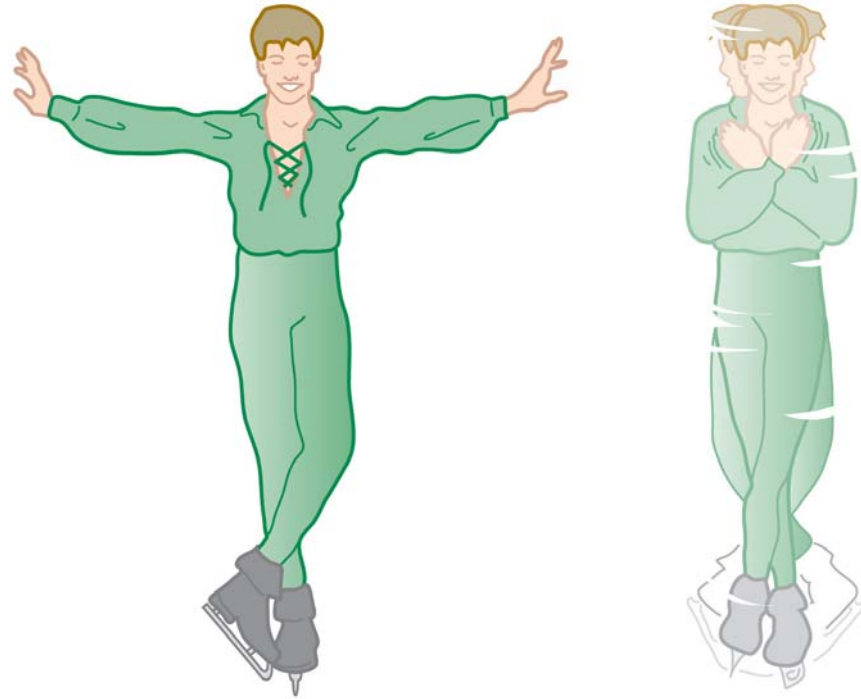

- A.  $L$  and  $K$  both increase.
- ✓ B.  $L$  stays the same;  $K$  increases.
- C.  $L$  increases;  $K$  stays the same.
- D.  $L$  and  $K$  both stay the same.